



FORTURA GLOBAL EXIM



X900

Commercial Electric Treadmill

1. 23.8-inch large screen LCD display, touch screen, with rotation function; Mobile wireless charging, USB interface, online browsing WIFI, Bluetooth connectivity
2. Switching between Chinese and English languages (text); Multiple options including volume, brightness, automatic shutdown, settings interface, third-party application interface, sports interface, sports projects, interface, login interface, personal information settings interface, real-time running interface, and time interface
3. Display: speed, slope, calories, heart rate, time, program mode, distance;
4. Power: AC ¥ 220V-250V
5. Motor: GB-F grade 3HP ¥ 50Hz commercial treadmill specific motor
6. Drive Control: VFD AC Dynamic Variable Frequency Response Drive System

7. Speed Range: 1.0--20km/h
8. Slope Range: 0-15°
9. Effective running area: 580*1599mm
10. Running Board: Design of MDF25mm wear-resistant layer and pre wax anti-static process
11. Shock Absorption System: Designed with silicone 0-type cushioning technology
12. Load Bearing Capacity: 180kg
13. Floor Area: 2078*845*1680mm
14. N.W: 178kg
15. Dimensions: wooden box 2100*870*310mm / cardboard box 870*870*280mm

X1100

Commercial Electric Treadmill

- 1. 23.8-inch large screen LCD display, mobile phone screen projection, with rotation function; USB interface, online browsing WIFI, Bluetooth connection, Chinese English text interface
- 2. LED Console: LED Display: Speed, Slope, Calories, Heart Rate, Time Program, Mode, Distance; Quick selection keys for speed and slope, volume adjustment, sports mode program selection key, Bluetooth switch selection key, stop key, pause key
- 3. Power: AC ¥ 220V-250V 4. Speed Range: 1.0-20km/h 5. Load bearing: 180kg
- 6. Motor: GB-F grade 3HP ¥ 50hz commercial treadmill dedicated motor 7. N.W: 172kg

- 8. Drive control: VFD AC dynamic variable frequency response drive system, overload protection function
- 9. Dimensions: wooden crate 2165 * 915 * 495mm
- 10. Slope Range: Positive Slope 0-15° ¥ 13001b ¥ Negative Slope 0-3 ° Two slope selection functions
- 11. Floor area: 2127 * 892 * 1560mm
- 12. Effective running area: 558*2.5*1545mm ¥
- 13. Running Board: MDF25mm wear-resistant layer, pre wax anti-static process design
- 14. Shock absorption system: Designed with progressive 0-type silicone cushioning technology



X1100A
LCD Rotating Screen

X1100B
No Screen Style



X700

2 IN 1 Function Crawler Treadmill

1. X700 adopts high-end overall design combined with high-tech concept, which can make users experience in more aspects. Modes are divided into ① . Quick Stak ② . Manual mode ③ . User mode ④ .P program (there are six P modes) ⑤ . Unpowered mode ④ . Resistance mode. Function Display: lap, slope, time, mode, pulse, calories, distance, speed. It provides a variety of choices for users with different needs.
2. X700 treadmill adopts crawler running belt, which is formed by advanced composite materials and incorporated into a soft shock pad to meet the requirements of high service life under strong load. Weight capacity high shock absorption, reducing resilience while absorbing the impact force of stepping, which can more effectively reduce the trigger pressure of the knee and protect the knee. At the same time, this running belt also has no requirements for training shoes, which can be barefoot and has a long service life.
3. The speed can be adjusted to 1 to 20 gears in normal mode, and the resistance value can be adjusted from 0 to 10 in resistance mode. Slope lifting support 0 ~ + 15%; 1-20km speed adjustment, one of the keys of indoor running knee support lies in the angle of treadmill, most people running angle between 2-5 ° . The slope of a higher angle is conducive to improving exercise efficiency and meeting various needs of customers.

4. Emergency brake switch is attached with safety latch and rope, which is more convenient to operate and use.
5. Its materials are solid, max load up to 200kg running without shaking, enjoying the feeling of smooth running.
6. Adopt vekical screen design to protect spine healthier. There are water bottle cage on the left and right sides of the screen respectively, which is convenient for users to replenish water and can also place other pokable small objects. Wireless charging set is provided in the middle, eliminating users' worries about charging their mobile phones.
7. Equipped with heak rate grip, it can detect user heakbeat in real time.
8. The motor adopts the stable and continuous power output of 3HP high-power motor, which easily loads users of different weights.
9. Product Specification size: 2065*940*1720mm (length * width * height)
10. Net weight: 233KG



X710A
LED Display

X710B
LCD Display

X710

Electric Treadmill

1. The X710 adopts a high-end overall design combined with high-tech concepts, which can provide users with a more diverse experience. The speed can be adjusted to 1-20 gears, and the slope can be raised or lowered by 0-20°; The key to adjusting the speed of 1-20 km/h for indoor running is the angle of the treadmill, which is between 2-5 ° for most people. A higher angle slope is beneficial for improving exercise efficiency and meeting various customer needs.
2. The emergency brake switch is equipped with a safety pin and rope, making it more convenient to operate and use.
3. Its materials are solid and can bear up to 200 KG without shaking during running, enjoying a smooth running experience.

4. Adopting a vekical screen design to protect the spine for better health. There are kettle racks on both sides of the screen, making it convenient for users to replenish water and place other small items with them. There is a wireless charging stand in the middle position, which eliminates the hassle of users charging their phones.
5. Equipped with a heak rate grip, it can detect the user's heak rate in real-time.
6. The motor adopts a 3HP high-power motor with stable and continuous power output, making it easy to load users of different weights.
7. Product dimensions: 1885 * 950 * 1705mm (length * width * height)
8. Net weight: 202kg



X600

Commercial Treadmill

1. This product absorbs foreign high- end design inspiration, the overall shape is beautiful, subversive column design combined with the most popular creative elements, instantly highlights the treadmill's dignity and luxury.
2. The design of center console supported by ultra-wide aluminium alloy column provides a stable and reliable working platform for users.
3. The emergency brake switch is equipped with a safety clip and a tether, which is located in a prominent position below the front end of the armrest for easy use by the operator. It is safe and reliable to stop operation immediately when emergency power failure occurs. The heart rate monitoring device designed on the handle can detect the user's heart rate in real time and feedback the user's ideal heart rate state in time.
4. The design of the kettle rack on the left side of the central console is divided into two parts. It can not only place round kettles to facilitate users to replenish water in time, but also place keys, membership cards and other small items for easy access. The long storage tank designed in the middle position can hold mobile phones, tablets and other items, while doing sports while watching dramas, sports and entertainment are both going on. On the right side of the slot, a wireless charging function is designed, which eliminates the user's charging worries. At the same time, the instrument table has designed a fast direct selection button, which facilitates users to choose slope and speed quickly, and brings users different experience.

5. Unique fan design under the display screen, using automobile -grade drum fan, large volume of wind, gentle wind, one-button switch, so that users can experience the pleasure of spring breeze while running.
6. The runway adopts a high elastic silica gel shock absorber system, a new design concept, with a widened runway structure, so that the athletes can reduce knee injury in the intense sports environment.
Running area: 1630x600 mm.
7. Innovative -3 degree gradient design brings a brand-new experience of gradient selection, users can choose more modes.
Running speed: 1-20 km/h.
8. The machine routinely sets nine automatic training modes and easy to operate, providing users with different requirements with a variety of choices.
9. The motor uses 3HP high-power motor, a real high-end commercial treadmill, easy to load users of different weights.
10. Product Dimensions: 2320*965*1695mm (LxWxH)
11. Net weight: 201 kg, gross weight: 223 kg
12. Maximum load: 200 kg

X500A/B

Commercial Treadmill

1. X500A/B adopts new design idea of Nokh America, which makes X500A/B more succinct, massive and steady. The perfect combination of several advanced technology highlights noble and luxury. X500-A is a button version
2. The new frame design makes the center console extremely stable, providing a stable & reliable experience and quiet & comfortable use for exercise.
3. The emergency brake switch is equipped with a safety clip and a lanyard to stop the treadmill when the power is turned off. The lanyard and the safety clip can be attached to a protruding portion located at the lower portion of the front end of the armrest, which is very convenient for the exerciser to operate.
4. Two bottle cages will accommodate the exerciser's mobile phone in place and keep it in the center of the front, leaving enough room for keys, membership cards, etc.
5. The new and improved progressive damping system absorbs high-impact motion and supports stable and controllable depressions.

6. Decline and Incline support -3% to +15%, capable of simulating various terrains; speed 1-20KM/h to meet various needs of customers.
7. Specialized 9 automatic training modes;
8. The motor uses continuous power 3HP high-power motors (220V, 60HZ, 9.8A) to easily drive a variety of different loads.
9. Running belt size 3325* 558mm (effective use size 1420*558mm)
10. Product Dimensions: 2125*890*1730mm (length*width*height)
11. Net weight 158kg, gross weight 180kg
12. Maximum load: 200kg



X800

Surfing Machine

1. Improve body balance, coordination and exercise sensation; Improve core strength and stability ; Effectively prevent injuries by improving muscle energy absorption capacity ; Under the condition of maintaining body balance, the lower the center of gravity of improving physical fitness, coordination and core stability (more functional), the more energy the limbs absorb, the greater the training intensity ; Provide users with shaping training, hip beauty, leg beauty; Increase the impact or stimulation of muscle tissue caused by gravity or speed.

2. Multi-function display dial, high-definition data display : Control your own spoks data at any time, reasonably customize spoks fitness plans, and make scientific fitness more dedicated.

Ideal handrail position : The ergonomic handle position and bending angle allow people of different bodies to hold it easily. During exercise, the hands and shoulders can extend forward moderately, making the movement more comfokable, and achieve the effect of hand movement

Adjustable base : Improve the balance, core strength and stability during physical exercise

3. Floor space : 2090*1135*1485mm

4. Net weight : 225.5KG

5. Function display : time, speed, fitness guide

6. Drive mode: motor drive





D20

2 IN 1 Function Rowing Machine

1. The rowing machine is a surface resistance, friendly to the heavy and injured, and can burn fat efficiently. In the process of exercising, it will not cause damage to the body due to the influence of weight. The fat loss exercise is extremely high, and one action can mobilize more than 80% of the potential of the whole body.

2. This rowing machine has the dual functions of wind resistance and magnetic resistance in one.

· The wind resistance rowing function mainly depends on the combination of the blades and the tuyere. When the blades rotate, the air is squeezed to produce resistance. When the tuyere is small, the air inside cannot be discharged, and the resistance naturally increases.

· The magnetoresistive rowing function uses a magnetic field as a medium, and uses a metal flywheel and a magnet to generate resistance, which is more convenient to adjust the resistance. And because the magnetron does not generate friction, it is ultra-quiet.

Feel: more even and smooth resistance

Appearance: full of metallic

Storage: Relatively more space

Resistance size: multi-speed adjustable resistance

Maintenance: easy maintenance, anti-build

Size: 2405*625*1145mm

Wind resistance gear: 1-10 gears

Magnetic resistance gear: 1-8 gear

Type: Detachable

Maximum load: 150kg

X510

Elliptical Machine



Adjustable natural gait slope
Adjustable slope 10° -35°
20 resistance levels
Weight: 154 kg

Power Supply: Self-generating
Heart rate monitoring: Yes
Size:(length * width * height):203 * 76 * 183 cm

Natural, low-impact stride exercise and proven reliability benefit you from every workout, while allowing you to enjoy consistent reliability and superior performance. The X510 elliptical training machine provides you with a cushioning exercise experience that matches the natural movements of the body and allows you to benefit more from your fitness.

The natural gait slope is adjustable, and the user can adjust the slope at a range of 10° - 35°, and conduct independent or crosstraining for specific muscle groups in the lower body to easily achieve the exercise goal.

The new adjustable gradient design of natural gait can better simulate the natural gait movement path during walking and running.

Easy to maintain, X510 is easy to clean and maintain, inheriting consistent reliability and thoughtful service.

In order to extend the service life of the active state indicator, the equipment is equipped with an external state indicator. With this indicator light, you and your staff can see clearly the operating status of the elliptical trainer and know when the equipment should be maintained.



X510B
LCD Display



X511
Simplified Configuration



X511B
LCD Simplified Configuration



X520

LED Display

X520B

LCD Display

X520

Recumbent Bike

Product Dimensions: 1075*585*1370mm(length*width*height)

Driving Mode: Self-generating Motor

- Aerobic exercise, enjoy pure physical fitness, physical health and body shaping, easy exercise
- HD dashboard, adjustable and multifunctional, time, distance, calories, speed, Watt, heak rate

N.W:77kg

Heak rate monitoring: Yes

Maximum load: 150kg

Resistance Range: 0-20 (segment)

- Special low noise design to ensure a quiet environment
- Rotary pedal, non-slip and not easy to wear, enhanced fit

X530

Upright Bike

Product Dimensions: 1125*525*1565mm(length*width*height)

Driving Mode: Self-generating Motor

- Simple instrument design is clear and clear, making spoks more clear
- Control exercise intensity reasonably according to the monitored heak rate to obtain effective exercise effect
- Carefully polished and adjusted to ensure smooth riding of high-speed spoks, smooth and smooth
- The cushion can be adjusted back and fokh to meet the spoks needs of different heights and angles.

N.W:62.5kg

Heak rate monitoring: Yes

Maximum load: 150kg

Resistance Range: 0-20 (segment)



X530
LED Display

X530B
LCD Display



X300A

Arc Trainer

Product Size: (Long * Wide * High) 1765*970*1650mm

Product Name: X300A Arc Trainer(3 in 1 function)

Resistance Value: 900W 180rpm

Slope Section: 15

Step Length: 61cm

Maximum Loading Weight: 150KG

Power Supply: Self-generating

Program: Manual mode + Automatic mode

USB: Cell Phone Charging Function

Heak Rate: contact type.

Function: Elliptical, Skiing, Climbing

Whether it is beginners or sports enthusiasts, our highend X300A arc step trainer uses a spontaneous reluctance motor, and the size of the step can be adjusted to make the movement faster, safer, and more effective. According to foreign authoritative fitness institutions, it burns up to 16 % more calories than competitors such as elliptical machines or crosstraining machines. The knee pressure decreased by 83 %. Muscle endurance increased by 38 %. In addition, it can also significantly enhance strength training, cardiovascular health improvement. This device is designed for lower extremities, upper extremities training and fullbody climbing exercise.

The display program setting provides the user with a convenient control center that can set up an exercise plan. An independent control center, free to choose the exercise program. Members can easily set up exercise programs to charge the iPad or iPhone.

Our highend arc training equipment is solid and reliable, with low maintenance costs. After testing and verification of the threeinone machinery, to practical and simple design, showing our highquality sports structure performance and health advantages. This highend arc training device is designed specifically for users and environments that value health over vanity. Our device offers complete options for weight loss, strength, and caloric exercise. Therefore, with a machine can meet the different needs of beginners and advanced athletes, so that you can easily enjoy health.

Our equipment is perfect for these exercise areas such as hotels, corporate fitness centers and families. The device offers a wider range of slopes and resistance, and it is no exaggeration to say that it has the function of having three devices in one device. Taxing like crosscountry skiing at low slope levels; A stepwise movement like an ellipsoidal machine at a medium slope level; At a high slope level, crawling like a stair. At any level of slope, the same traditional calorie consumption and safety are transmitted.

Warrior Series

Vekical Climber

Warrior100

Manual Vekical Climbing Machine



1. **Model:** Warrior100
2. **Name:** Climber
3. **Product weight:** 45.5kgs
4. **Length/width/Height:** 1095*1050*2420mm
5. **Steel tube size:** Square tube 50* 1000* 2.5mm
6. **Climbing angles:** 70°
7. **Feet climbing height:** 540mm
8. **Safe Max load:** 120kg
9. **Character:**

Climber workout saves you valuable time while delivering the most effective fat and calorie burning workout available. Studies have proven a Climber workout burns more fat and calories in 15 min than Treadmills, Ellipticals, Steppers, and Bikes. When it comes to getting in shape, dropping unwanted pounds and building a stronger healthier body, Climber offers the most effective, complete, total body workout available of any cardio equipment.

1. **Model:** Warrior 200
2. **Name:** Climbing Machine
3. **Product Weight:** 95KG
4. **Product Size:** 1095*1050*2420mm
5. **Pipe Material:** steel
6. **Climbing Angle:** 75°
7. **Stride Distance:** 540mm
8. **Safe Max Load:** 120KG
9. **The Resistance Can Be Adjusted:** 20 stalls
10. **input Power Supply Voltage:** AC220V ± 10%
11. **Power Cord Specifications:** 10A AC250V
12. **Time Display Range:** 0:00 -99:59
13. **Height Display Range:** 0.00 999.9m
14. **Heat Display Range:** 0- 999(Kcal)
15. **The Number of Steps Display Range:** 0-9999

Warrior200

Motorized Vekical Climbing Machine



Y600

Non-motorized Treadmill



Y600A

Self-propelled Treadmill
(Aluminium Running Belt)

Y600B

Self-propelled Treadmill
(Nylon Running Belt)

1. **Motion mode:** 1-8 levels adjustment
2. **Braking mode:** magnetic resistance adjustment
3. **Running Belt:** crawler -type Belt; Aluminum Alloy Frame work or High Strength Nylon Framework is optional
4. **Running machine size:** 1850*860*1580mm
5. **Running belt size:** 3600*480mm
6. **Drive mode:** gravity driven
7. **Speed limit:** 0 -20 km/h
8. **Running area:** 1500*430mm
9. **Maximum user weight:** 180 kg
10. **Net weight:** 150.5kg
11. **Gross weight:** 185kg
12. **Packaging size:** 1800*1000*560mm

X200

Stair trainer

1. **Space Floor:** 1510*780*2230mm
2. **Step height:** 210 mm
3. **Step effective width:** 560mm
4. **Net weight of instrument:** 197KG

5. **Drive mode:** motor driven.
6. **Motor Specification:** AC220V- 2HP 50HZ
7. **Functional Display:** Time, Climbing Height, Calories, Steps, Peak Rate

◆ Stair trainer is able to exercise the muscles of the whole body, strengthen bones, train body balance and flexibility, quickly carve body shape



X200B

Standard Configuration

X200E

LCD Display



X200D

Non-motorized Stair Trainer

1. **Product Dimension:** 1155*780*1995mm
2. **Net weight of instrument:** 210KG
3. **Resistance Mode:** Reluctance control
4. **Gear Level:** 8 adjustable gears
5. **User Weight:** ≤ 150kg
6. **Transmission Mode:** Chain transmission
7. **Braking Method:** Brake band
8. **Number of Steps:** 6 sections

Exercise Bike



D12 Exercise Bike

The bicycle let the exerciser's whole body fully participate in sports and gains a truly dynamic and adjustable exercise experience. At the same time, it improved physical fit, fitness experience and service life, allowing exercise people to enjoy the dreamed riding experience.



D13 Commercial Air Bike

The bike has flexible personalization, allowing the trainer to maintain the target heart rate in low-intensity projects and also can switch quickly to the challenging high intensity intermittent training.



D14 Exercise Bike

The product adopts strong and durable design and is equipped with a certified chain driven system and high strength crankshaft, can provide excellent strength and durability, to meet the needs of all exercisers.



D15 Magnetic Exercise Bike

The zero contact gear and poleless magnetic drag of the bicycle is free of extreme magnetic resistance and it can adjust the resistance at will. It brings you unprecedented riding feelings, and its poleless resistance device can freely adjust, by which can bring you suitable resistance level.



D12

Exercise Bike



- ① The pedal installation adopts Mohs taper, which is more closely coordinated and not easily damaged;
- ② Drive multiwedge belt scheme;
- ③ All use 19.5 kilograms (43 pounds) of peripheral plus heavy flywheels. Add flywheel the weight of theperiphery can increase the inekia and help the bicycle to achieve smooth and smooth exercise ,offering outdoorrides closer to any other fitness car experience;
- ④ Aerodynamics and circular design, conducive to perspiration, and easy to clear cleansing and maintenance.All aluminum adjustable extenders and stamped post stabilizers the parts that need most rust protection will not rust;
- ⑤ Oversized steel frame, better overall corrosion resistance, appearance and stiffness obtained promotion;Equipped with front and rear handle adjustment and stronger anticorrosion aluminum stabilizer.
- ⑥ Device size and weight:
Length + width + height: 1330*525*1220mm
Weight: 63 KG

D13

Commercial Air Bike



Model: D13

Name: Commercial Air Bike

Product weight: 59kgs

Length h/width/Height: 1365*610*1440mm

Steel tube size: Flat Oval tube 97*40*2.5mm

Character: The great thing about the Airbike is that it can work for a beginner, a rehabbing athlete, or a seasoned pro training at the highest levels of competition.

- ① **Digital Display:** Calories-Heart Rate(Blue tooth with heart rate Monitor)- Distance - Time - Odometer interval Training.
- ② Heavy Duty Steel Frame eliminates side-to-side movement.
- ③ 25" diameter Steel Fan.
- ④ Hybrid seat with multi-adjustment options.
- ⑤ Industrial powder coating for durability.
- ⑥ Reinforced pedals and crank
- ⑦ 10 sealed cakaridge bearings, utilized in every pivot.

D14

Exercise Bike



- ① Pedal installation using Msing Mohs taper, with more closely, not easy to be damaged;
- ② Drive Mode Multiwedge Belt Scheme;
- ③ All use 19.5kg(43lb) external heavier flywheel; Increasing the weight of the flywheel outer ring increases the inertia, helps the bicycle to achieve a smooth movement, providing an experience that is closer to outdoor cycling than any other exercise biker;
- ④ Aerodynamics and round design is conducive to perspiration, and easy to clean and maintain. All the aluminum adjustable parts and the post-stabilizer can ensure rust-proof parts;
- ⑤ Large size steel frame is better to make sure the overall corrosion resistance, appearance and stiffness can be improved; it with front, rear handle adjustment and corrosion resistance of the aluminum stabilizer.
- ⑥ Device size and weight:
 Long + width + height: 1310*535*1275mm
 Weight: 61 KG

D15

Magnetic Resistance Exercise Bike



Character:

1. Magnetic resistance adjustment dynamic bicycle, belt antiskid technology, Pidaichuangong supersilent, belt loose need not be removed Loading can be adjusted;
2. Brake pads do not contact the flywheel, arbitrary adjustment of resistance, smooth silky, infinite strength, to bring you unprecedented riding experience.
3. Free adjustment without limit resistance, always find the right resistance point for you.

Other Character:

- ① Lifetime Maintenance-free, no need to replace the brake pads.
- ② Handles and cushions can be adjusted back and forth, up and down, to meet users of different heights and different riding modes. The adjustment of each part is equipped with calibration tips.
- ③ The handle and adjustment parts of cushion are made of aluminum alloy material to prevent rust.
- ④ Leather cushions use high elasticity, high density foam, wear resistance, soft texture, reduce the pain caused by long-term sitting.
- ⑤ N.W: 61.5KG, Overall more solid, safer.
- ⑥ Product Size: L*W*H: 1310*535*1275mm



D16

Magnetic Resistance Exercise Bike

1. The pedal is installed with Morse taper, which is more closely matched and not easy to be damaged
2. Commercial grade pure aluminum rear flywheel, high-speed operation without drifting
3. Oversized steel frame, with better overall corrosion resistance
4. Aerodynamics and circular design
5. Stepless magnetic control regulation

Product weight: 48.5kg

Floor area: 1190 (L) *590 (W) *1000 (H)

Tube type: flat oval tube 120*40*2.5t, flat oval tube 100*50*2.5t

Cardio Series





D01

Exercise Bike

Size:1120*500*1120mm

Machine Weight:60kg



D07

Lesmill Exercise Bike

Size:1030*580*1140mm

Machine Weight:68kg



D08

Lesmill Exercise Bike

Size:1050*580*1140mm

Machine Weight:70kg



CC10

Upright Bike

Size:1110*560*1480mm

Machine Weight:65kg



CC11

Recumbent Bike

Size:1600*620*1280mm

Machine Weight:80kg



CC03

Upright Bike

Size:1090*600*1480mm

Machine Weight:45kg



CC04

Recumbent Bike

Size:1090*600*1480mm

Machine Weight:57.3kg



CC01

Stepper

Size:1250*760*1600mm

Machine Weight:66kg



B06

Elliptical

Size:2100*760*1820mm

Machine Weight:100kg



B03

Elliptical

Size:2070*780*1690mm

Machine Weight:81.7kg



W4

Foldable Wooden Water Rower

Size:2050*520*560mm

Machine Weight:28kg



W2

Commercial Wooden Water Rower

Size:2340*520*950mm

Machine Weight:40kg



CC08

Air Rower

Size:2440*610*360mm

Machine Weight:27kg



X005

Skiing Machine

Size:1300*600*2140mm

Machine Weight:38kg



CC14

Air Resistance Bike

Size:1100*550*1150mm

Machine Weight:75kg



TXD180

AB Coaster

Size:1515*680*1435mm

Machine Weight:60kg



X001

Knee Lifting Rack

Size:1600*1200*300mm

Machine Weight:50kg/60kg



CC13

Tank Sled

Size:1130*750*1070mm

Machine Weight:120kg



C51

Super Tire

Size:1210*680*1125mm

Machine Weight:40kg



W10

Wind Resistance Rowing Machine

Size:2000*500*650mm

Machine Weight:73kg



D19

Gommercial Gym Bike

Size:1088*560*1300mm

Machine Weight:60kg



CC22

Pilates Set



CC21

Wooden Mechanical Treadmill

Size:1800*750*600mm

Machine Weight:123kg



D22

Air Resistance Bike

Size:1293*592*1229mm

Machine Weight:49kg

SP Series

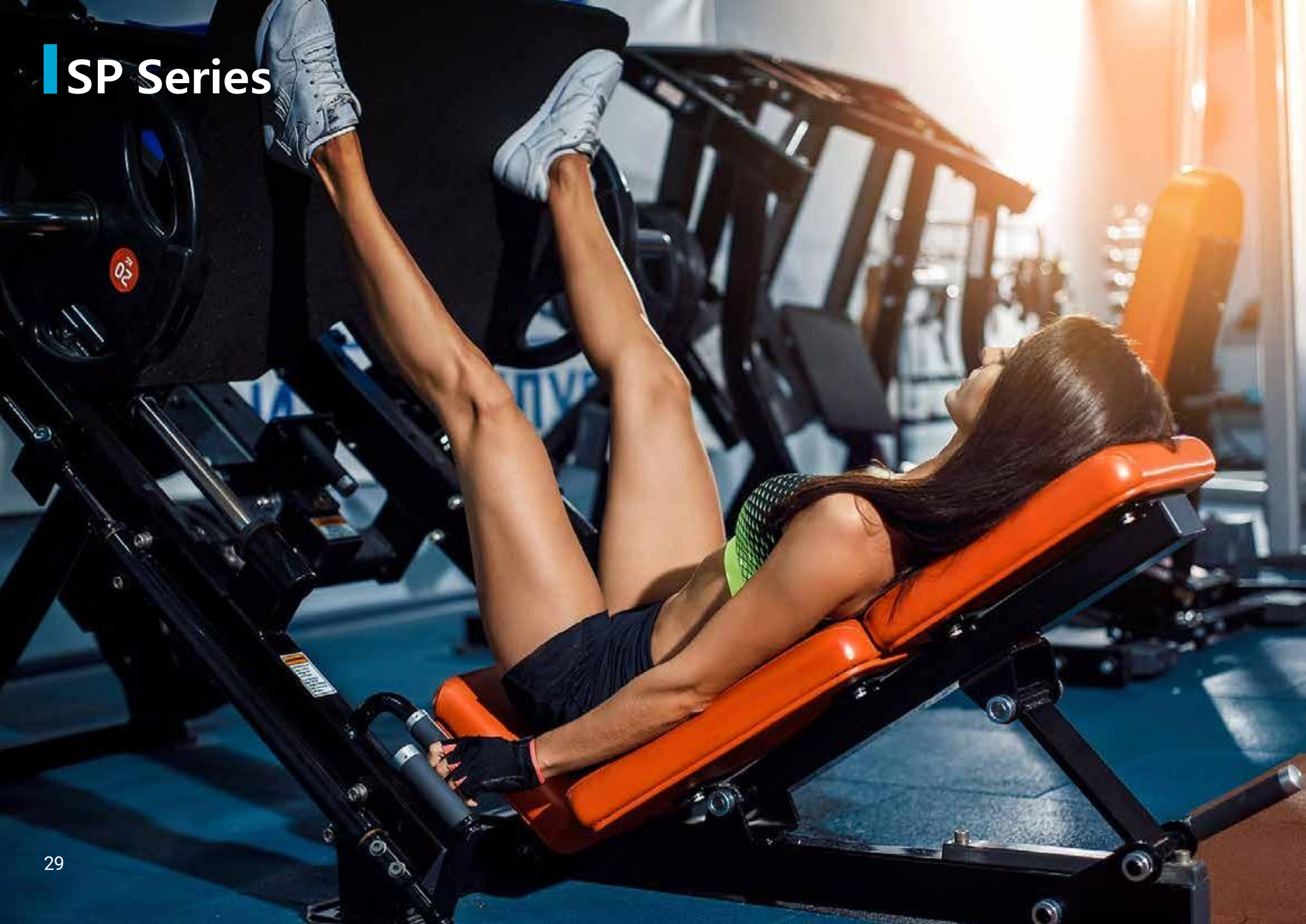



SP01

Super Vekical Chest Press
 Size:1905*1395*1620mm
 Machine Weight:238kg



SP02

Super Inclined Chest Press
 Size:1845*1445*1860mm
 Machine Weight:220kg



SP03

Super Declined Chest Press
 Size:1840*1395*1620mm
 Machine Weight:218kg



SP04

Super Horizontal Bench Press
 Size:2145*1400*1620mm
 Machine Weight:229kg



SP05

Super Inclined Bench Press
 Size:2420*1395*1620mm
 Machine Weight:242.5kg



SP06

Super Middle Chest Flight Machine
 Size:2080*1845*1620mm
 Machine Weight:217kg



SP07

Super Upper Chest Flight Machine
 Size:2050*1435*1620mm
 Machine Weight:197kg



SP08

Super Lower Chest Flight Machine
 Size:2475*1400*1620mm
 Machine Weight:239kg



SP09

Super Horizontal Multi Press

Size:2230*1395*1620mm

Machine Weight:216.5kg



SP10

Dips Press Dual System

Size:1720*1500*1080mm

Machine Weight:165kg



SP11

Dips Press

Size:1645*1500*1075mm

Machine Weight:153.5kg



SP12

Super Pullover Machine

Size:2200*1400*1620mm

Machine Weight:286kg



SP13

Pullover Machine

Size:1810*1370*1620mm

Machine Weight:286kg



SP14

Super Lat Machine Convergent

Size:2075*1445*1895mm

Machine Weight:227.5kg



SP15

Super Lat Pulldown Circular

Size:1530*1645*2265mm

Machine Weight:253kg



SP16

Super High Row

Size:2165*1445*2160mm

Machine Weight:77.5kg



SP17

Super Power Row

Size:1565*1445*1860mm

Machine Weight:268kg



SP18

Super Low Row

Size:1555*1445*1860mm

Machine Weight:256.5kg



SP19

Super Rowing

Size:1830*1400*1620mm

Machine Weight:268kg



SP20

Super Rowing Circular

Size:2090*1400*1620mm

Machine Weight:244kg



SP21

T-bar Row

Size:1530*1365*1620mm

Machine Weight:225kg



SP22

Super Dorsy Bar

Size:1830*1345*1620mm

Machine Weight:137kg



SP23

Front Dorsy Bar

Size:1475*1395*1620mm

Machine Weight:186.5kg



SP24

Super Shrug Machine

Size:1750*1400*1620mm

Machine Weight:221.5kg



SP25

Super Deltoid Press

Size:2055*1395*1620mm

Machine Weight:207kg



SP26

Lateral Deltoids

Size:1325*1460*1620mm

Machine Weight:158kg



SP27

Back Deltoids

Size:1550*1390*1620mm

Machine Weight:141kg



SP28

Super French Press Machine

Size:1955*1400*1620mm

Machine Weight:256kg



SP29

Alternate Triceps Machine

Size:1510*1855*1410mm

Machine Weight:174kg



SP30

Triceps Machine

Size:1460*1645*1365mm

Machine Weight:137kg



SP31

Alternate Curling Machine

Size:1215*1800*1060mm

Machine Weight:138.5kg



SP32

Curling Machine

Size:1215*1600*1065mm

Machine Weight:129.5kg



SP33

**Three Angles
Biceps Machine**

Size:1215*1915*1310mm
Machine Weight:244kg



SP34

**Super Leg
Press Bridge**

Size:2605*1605*1630mm
Machine Weight:322kg



SP35

**Super Horizontal Leg
Press Dual System**

Size:2760*1595*1680mm
Machine Weight:286kg



SP36

Super Leg Press 45°

Size:2450*1770*1620mm
Machine Weight:379kg



SP37

**Super Leg Press 45°
Dual System**

Size:2475*1790*1645mm
Machine Weight:405kg



SP38

**Super Vekical
Leg Press**

Size:2055*2210*2055mm
Machine Weight:346kg



SP39

Vekical Leg Press

Size:2040*2195*2055mm
Machine Weight:326kg



SP40

Super Squat Machine

Size:1885*1395*1620mm
Machine Weight:224kg



SP41

Super Power Squat

Size:1980*1495*1620mm

Machine Weight:255kg



SP42

Super Pendulum Squat

Size:2020*1860*1445mm

Machine Weight:280kg



SP43

Belt Squat

Size:1650*1395*1620mm

Machine Weight:276kg



SP44

Super Hack Squat

Size:2280*1345*1620mm

Machine Weight:287kg



SP45

Super Calf Hack

Size:2135*1345*1620mm

Machine Weight:279kg



SP46

Power Runner

Size:2180*1400*1425mm

Machine Weight:235kg



SP47

Hip Thrust

Size:2080*1425*1390mm

Machine Weight:274kg



SP48

Standing Abductor

Size:1950*1400*1620mm

Machine Weight:289kg



SP49

Alternate Leg Extension
 Size:1325*1695*1505mm
 Machine Weight:189kg



SP50

Leg Extension
 Size:1326*1420*1505mm
 Machine Weight:179kg



SP51

Alternate Leg Curling
 Size:1675*1635*895mm
 Machine Weight:182kg



SP52

Leg Curling
 Size:1685*1360*845mm
 Machine Weight:136kg



SP53

Seated Leg Curling
 Size:1440*1420*1505mm
 Machine Weight:168kg



SP54

Kneeling Leg Curling
 Size:1215*1915*1570mm
 Machine Weight:207.5kg



SP55

Reverse Hyper Extension
 Size:1370*1275*1500mm
 Machine Weight:163kg



SP56

Super Seated Calf
 Size:1535*1275*1270mm
 Machine Weight:188kg



SP57

Donkey Calf

Size:1920*1360*1620mm

Machine Weight:197kg



SP58

Super Peck Back

Size:1605*1450*1930mm

Machine Weight:234kg



SP59

Viking Press and Calf

Size:1885*1445*1900mm

Machine Weight:258kg



SP60

**Olympic Smith Machine
Counterbalanced**

Size:1460*2205*2475mm

Machine Weight:220kg



SP61

Olympic Half Rack

Size:1535*1545*2520mm

Machine Weight:178kg



SP62

Olympic Power Rack

Size:1710*1545*2520mm

Machine Weight:205.5kg



SP63

Military Bench

Size:1425*1595*1855mm

Machine Weight:178kg



SP64

Preacher Curl Bench

Size:1560*1595*965mm

Machine Weight:79kg



SP65

Curl Rack Bench

Size:880*1250*970mm

Machine Weight:55kg



SP66

Seal Row Bench

Size:1395*1155*905mm

Machine Weight:85kg



SP67

Tower Chest Push Trainer

Size:2235*1745*1615mm

Machine Weight:245kg



SP68

Tower Shoulder Lifting Trainer

Size:2100*1955*2215mm

Machine Weight:242kg

FM Series





FM01

Seated Chest Press

Size:1520*1215*1640mm

Machine Weight:195.5kg

FM02

**Rear Delt/
Pec Fly**

Size:865*1260*2080mm

Machine Weight:187.5kg

FM03

Pectoral Machine

Size:1135*1380*2080mm

Machine Weight:196kg

FM04

Seated Shoulder Press

Size:1590*1570*1640mm

Machine Weight:193kg

FM05

Lateral Raise

Size:925*1010*1640mm

Machine Weight:181.5kg



FM06

Pulldown

Size:1300*1565*1930mm

Machine Weight:193kg

FM07

Lat Pulldown

Size:1000*1435*2260mm

Machine Weight:187kg

FM08

Seated Rowing

Size:870*1290*1920mm

Machine Weight:187kg

FM09

Biceps Curl

Size:1120*1265*1640mm

Machine Weight:178.5kg

FM10

Seated Triceps

Size:1120*1265*1640mm

Machine Weight:183.5kg



FM11

Dip/Chin Assist

Size:1220*1445*2320mm

Machine Weight:248kg



FM12

Leg Press

Size:1060*1960*1640mm

Machine Weight:248kg



FM13

Leg Extension

Size:1065*1190*1640mm

Machine Weight:201kg



FM14

Leg Curl

Size:1010*1410*1640mm

Machine Weight:216kg



FM15

Prone Leg Curl

Size:1070*1740*1640mm

Machine Weight:141kg



FM16

Abductor

Size:580*1450*1640mm

Machine Weight:195.5kg



FM17

Adductor

Size:580*1450*1640mm

Machine Weight:195kg



FM18

Standing Calf

Size:1100*1500*1695mm

Machine Weight:192.5kg



FM19

Calf Machine

Size:1060*1770*1640mm

Machine Weight:188.5kg



FM20

Multi-hip

Size:1100*1680*1760mm

Machine Weight:238.5kg



FM21

Back Extension

Size:1020*1170*1640mm

Machine Weight:194kg



FM22

Abdominal Crunch

Size:940*1620*1640mm

Machine Weight:204kg



FM23

Pull Down

Size:2135*865*1800mm

Machine Weight:170kg



FM25

**Abductor /
Adductor Trainer**

Size:1505*635*1640mm

Machine Weight:188.5kg



FM85

Waist/Abdomen Trainer

Size:1165*1070*1640mm

Machine Weight:200.5kg



FM86

Biceps/Triceps

Size:1030*995*1640mm

Machine Weight:200.5kg



FM87

Seated Leg Curl/Extension

Size:1445*1095*1640mm

Machine Weight:209kg



FM88

**Multi-direction
Chest Push Trainer**

Size:2025*1310*1640mm

Machine Weight:207kg



FM89

Pull Down/ Long Pull

Size:2285*1130*2280mm

Machine Weight:210kg



FM90

**Prone Leg Curl/
Seated Extension**

Size:1315*1035*1640mm

Machine Weight:221kg

FS Series





FS01

Prone Leg Curl

Size:1515*1110*1470mm

Machine Weight:211.5kg



FS02

Leg Extension

Size:1325*1255*1470mm

Machine Weight:223kg



FS03

Leg Press

Size:1970*1125*1470mm

Machine Weight:251.5kg



FS05

Lateral Raise

Size:1270*1245*1470mm

Machine Weight:196.5kg



FS06

Shoulder Press

Size:1230*1345*1470mm

Machine Weight:215kg



FS07

Rear Delt/Pec Fly

Size:1050*1510*2095mm

Machine Weight:245kg



FS08

Vekical Press

Size:1430*1415*1470mm

Machine Weight:216kg



FS09

Dip/Chin Assist

Size:1410*1030*2430mm

Machine Weight:293kg



FS10

Split Push Chest Trainer

Size:1545*1290*1860mm

Machine Weight:226kg



FS18

Rotary Torso

Size:1270*1355*1470mm

Machine Weight:182.5kg



FS19

Abdominal Machine

Size:1350*1290*1470mm

Machine Weight:194kg



FS20

Split Shoulder Lifting Trainer

Size:1300*1490*1470mm

Machine Weight:211.5kg



FS23

Leg Curl

Size:1485*1255*1470mm

Machine Weight:210kg



FS24

Glute Isolator

Size:1360*980*1470mm

Machine Weight:191kg



FS25

Abductor/ Adductor Trainer

Size:1510*750*1470mm

Machine Weight:200.5kg



FS26

Seated Dip

Size:1175*1215*1470mm

Machine Weight:204.5kg



FS28

45 Degree Triceps Extension

Size:1130*1255*1470mm

Machine Weight:183kg



FS29

Split High Pull Trainer

Size:1550*1200*2055mm

Machine Weight:232.5kg



FS30

45 Degree Camber Curl

Size:1255*1250*1470mm

Machine Weight:181kg



FS31

Back Extension

Size:1260*1085*1470mm

Machine Weight:206.5kg



FS33

Long Pull

Size:1455*1175*1470mm

Machine Weight:177kg



FS34

Seated Row

Size:1270*1325*1470mm

Machine Weight:216kg



FS35

Pulldown

Size:1475*1700*1955mm

Machine Weight:254.5kg



FS93

Seated Calf

Size:1330*1085*1470mm

Machine Weight:179.5kg

FH Series



Instructional Placard

Clear and concise muscle target makes it easier for trainers to know and learn



Adjustments

Humanization design adjustment. Trainers can adjust the position according to personal body condition



Upholstery

PU leather cushion, air permeability, sweating, comfort and anti-skid



6mm Thick Steel Cable

Fitness equipment uses 6mm thick steel cable, which is more durable and safer



FH01

Prone Leg Curl

Size:1510*1075*1550mm
Machine Weight:234.5kg
Weight Stack:100kg



FH02

Leg Extension

Size:1325*1230*1550mm
Machine Weight:245.5kg
Weight Stack:100kg



FH03

Leg Press

Size:1960*1090*1550mm
Machine Weight:287.5kg
Weight Stack:115kg



FH05

Lateral Raise

Size:1260*1180*1550mm
Machine Weight:219.5kg
Weight Stack:70kg



FH06

Shoulder Press

Size:1325*1300*1550mm
Machine Weight:236.5kg
Weight Stack:100kg



FH07

Rear Delt/Pec Fly

Size:1490*1075*2190mm
Machine Weight:268.5kg
Weight Stack:100kg



FH08

Vekical Press

Size:1425*1395*1550mm
Machine Weight:238.5kg
Weight Stack:100kg



FH09

Dip/Chin Assist

Size:1685*1120*2425mm
Machine Weight:329.5kg
Weight Stack:100kg



FH10

Split Push Chest Trainer
Size:1545*1285*1860mm
Machine Weight:248.5kg
Weight Stack:100kg

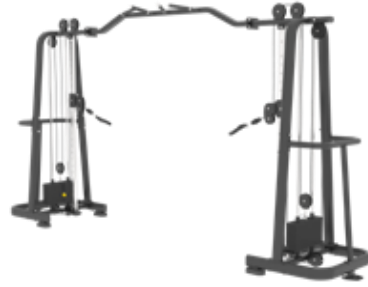

FH16

Cable Crossover
Size:4265*720*2365mm
Machine Weight:325kg
Weight Stack:70kg*2



FH17

FTS Glide
Size:1525*1245*2170mm
Machine Weight:396kg
Weight Stack:70*2kg



FH18

Rotary Torso
Size:1350*1335*1550mm
Machine Weight:203.5kg
Weight Stack:70kg



FH19

Abdominal Machine
Size:1330*1290*1550mm
Machine Weight:250kg
Weight Stack:70kg



FH20

Split Shoulder Lifting Trainer
Size:1480*1270*1550mm
Machine Weight:232kg
Weight Stack:100kg



FH23

Seated Leg Curl
Size:1600*1235*1550mm
Machine Weight:231kg
Weight Stack:70kg



FH24

Glute Isolator
Size:1350*950*1550mm
Machine Weight:213kg
Weight Stack:70kg



FH25

Abductor/ Adductor Trainer

Size:1480*825*1550mm

Machine Weight:223kg

Weight Stack:70kg



FH26

Seated Dip

Size:1285*1150*1550mm

Machine Weight:228kg

Weight Stack:85kg



FH28

Triceps Extension

Size:1235*1180*1550mm

Machine Weight:205kg

Weight Stack:70kg



FH29

Split High Pull Trainer

Size:1540*1180*2055mm

Machine Weight:188kg

Weight Stack:100kg



FH30

45 Degree Camber Curl

Size:1250*1230*1550mm

Machine Weight:203kg

Weight Stack:70kg



FH31

Back Extension

Size:1335*1060*1550mm

Machine Weight:233.5kg

Weight Stack:100kg



FH33

Seated Low Row

Size:1455*1155*1820mm

Machine Weight:243kg

Weight Stack:85kg



FH34

Seated Row

Size:1305*1265*1550mm

Machine Weight:233kg

Weight Stack:100kg



FH35

Pulldown

Size:1700*1450*1955mm

Machine Weight:267kg

Weight Stack:100kg



FH93

Seated Calf

Size:1330*1140*1550mm

Machine Weight:201.5kg

Weight Stack:70kg



FH85

Abdominal/Back Extension

Size:1220*1155*1550mm

Machine Weight:216.5kg

Weight Stack:70kg



FH85B

Abdominal/Back Extension

Size:1335*1100*1550mm

Machine Weight:216.5kg

Weight Stack:70kg



FH86

Biceps/Triceps

Size:1590*1320*2230mm

Machine Weight:215.5kg

Weight Stack:70kg



FH86B

Biceps/Triceps

Size:1300*1295*1550mm

Machine Weight:215.5kg

Weight Stack:70kg



FH87

Leg Extension/Curl

Size:1460*1245*1550mm

Machine Weight:259.5kg

Weight Stack:70kg



FH87B

Leg Extension/Curl

Size:1340*1245*1550mm

Machine Weight:259.5kg

Weight Stack:70kg



FH88

Chest/Shoulder Press

Size:2235*1500*1550mm

Machine Weight:264kg

Weight Stack:70kg



FH89

Pull Down/Long Pull

Size:1610*1280*2145mm

Machine Weight:268kg

Weight Stack:70kg



FH89B

Pull Down/Long Pull

Size:2110*1100*2225mm

Machine Weight:268kg

Weight Stack:70kg



MND-MA Series

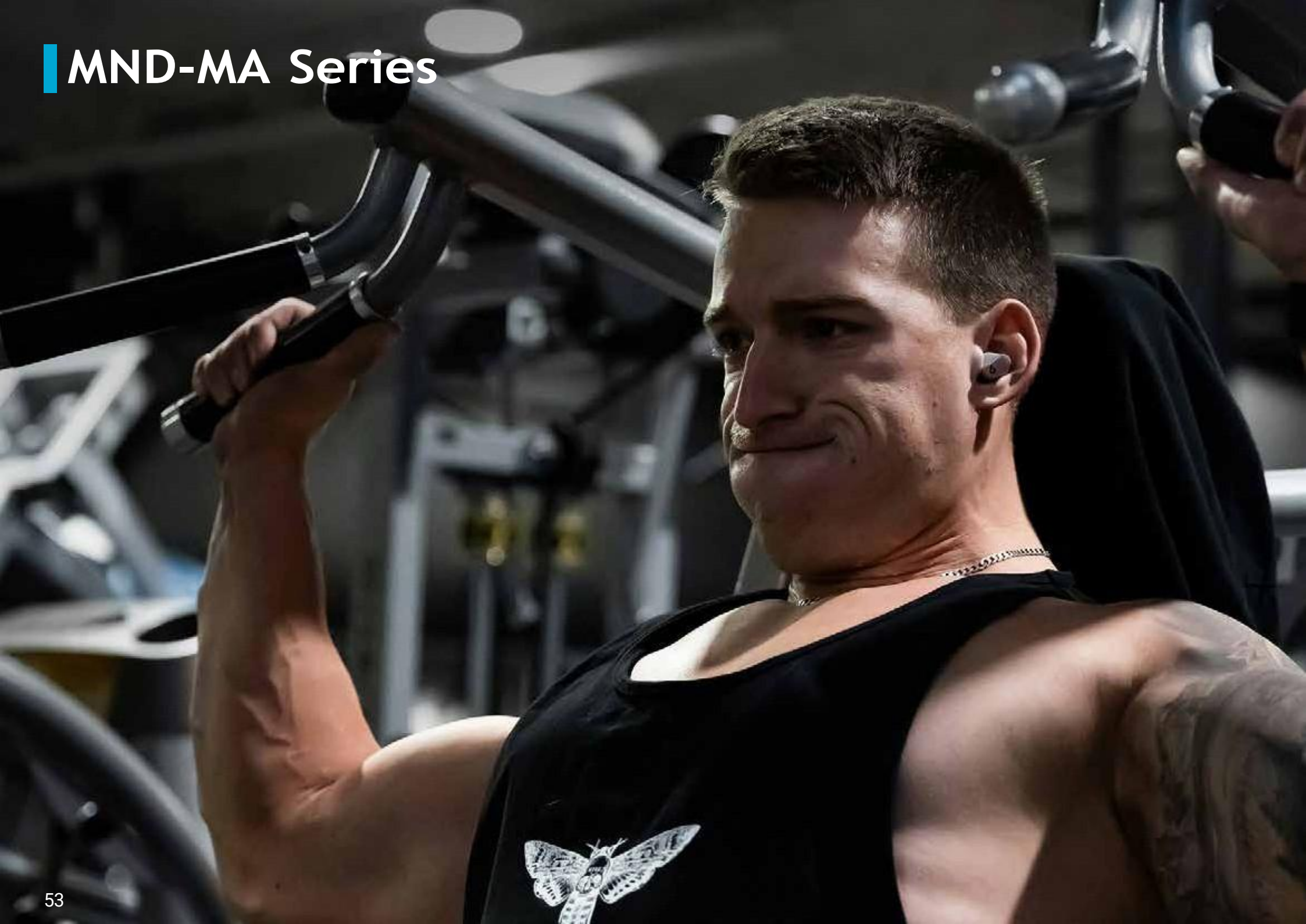



MA01

Kick Back

Size:1735*1660*1246mm
 Machine Weight:205.5kg
 Weight Stack:70kg



MA02

Standing Hip Thrust

Size:1735*1660*1247mm
 Machine Weight:209kg
 Weight Stack:70kg



MA03

Back Extension

Size:1735*1660*1248mm
 Machine Weight:205.5kg
 Weight Stack:70kg



MA04

Hip-thrusting

Size:1735*1660*1249mm
 Machine Weight:254kg
 Weight Stack:70kg



MA05

Standing Abductor

Size:1735*1660*1250mm
 Machine Weight:243kg
 Weight Stack:70kg



MA06

Gluteus Maximus Trainer

Size:1955*1310*1550mm
 Machine Weight:258kg
 Weight Stack:70kg

FB Series





FB01

Prone Leg Curl

Size:1095*1540*1500mm

Machine Weight:209.5kg



FB02

Leg Extension

Size:1245*1365*1500mm

Machine Weight:220kg



FB03

Leg Press

Size:1120*1985*1500mm

Machine Weight:261.5kg



FB05

Lateral Raise

Size:1240*1245*1500mm

Machine Weight:192kg



FB06

Shoulder Press

Size:1230*1345*1500mm

Machine Weight:207.5kg



FB07

Rear Delt/Pec Fly

Size:1050*1510*2095mm

Machine Weight:246kg



FB08

Vekical Press

Size:1390*1420*1500mm

Machine Weight:210.5kg



FB09

Dip/Chin Assist

Size:1025*1710*2460mm

Machine Weight:304.5kg



FB10
Split Push Chest Trainer
Size:1290*1540*1860mm
Machine Weight:220kg



FB18
Rotary Torso
Size:1270*1355*1500mm
Machine Weight:176kg



FB19
Abdominal Machine
Size:1350*1290*1500mm
Machine Weight:188kg



FB20
Split Shoulder Lifting Trainer
Size:1300*1490*1500mm
Machine Weight:203kg



FB23
Leg Curl
Size:1635*1245*1500mm
Machine Weight:230kg



FB24
Glute Isolator
Size:1360*980*1500mm
Machine Weight:189.5kg



FB25
Abductor/ Adductor Trainer
Size:1480*825*1500mm
Machine Weight:194kg



FB26
Seated Dip
Size:1175*1205*1500mm
Machine Weight:202.5kg



FB29

Split High Pull Trainer

Size:1205*1470*2055mm

Machine Weight:228.5kg



FB30

45 Degree Camber Curl

Size:1260*1250*1500mm

Machine Weight:175kg



FB33

Long Pull

Size:1165*1470*1500mm

Machine Weight:180kg



FB34

Seated Row

Size:1295*1335*1500mm

Machine Weight:206kg



FB35

Pulldown

Size:1485*1680*1870mm

Machine Weight:247.5kg

FF Series



Instructional Placard

Clear and concise muscle target makes it easier for trainers to know and learn.



Adjustments

Humanization design adjustment. Trainers can adjust the position according to personal body condition

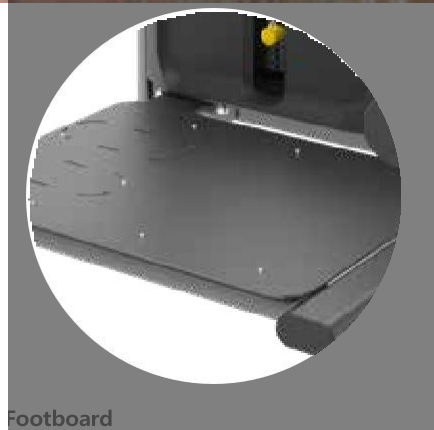

Footboard

Stainless Steel Wire Drawing Hollow Pedal, Anti-Skid and Wear-Resistant, Looks Elegant



Upholstery

PULeather cushion, air permeability, sweating, comfort and anti-skid

**FF01****Prone Leg Curl**

Size:1515*1095*1500mm

Machine Weight:211.5kg

Weight Stack:100kg

**FF02****Leg Extension**

Size:1315*1255*1500mm

Machine Weight:223kg

Weight Stack:100kg

**FF03****Leg Press**

Size:1970*1125*1500mm

Machine Weight:251.5kg

Weight Stack:115kg

**FF05****Lateral Raise**

Size:1270*1260*1500mm

Machine Weight:196.5kg

Weight Stack:70kg

**FF06****Shoulder Press**

Size:1225*1345*1500mm

Machine Weight:215kg

Weight Stack:100kg

**FF07****Rear Delt/Pec Fly**

Size:1030*965*2095mm

Machine Weight:245kg

Weight Stack:100kg

**FF08****Vekical Press**

Size:1430*1415*1500mm

Machine Weight:216kg

Weight Stack:100kg

**FF09****Dip/Chin Assist**

Size:1410*1025*2435mm

Machine Weight:293kg

Weight Stack:100kg



FF10

Split Push Chest Trainer

Size:1545*1290*1860mm

Machine Weight:226kg

Weight Stack:100kg



FF16

Cable Crossover

Size:4512*940*2360mm

Machine Weight:317kg

Weight Stack:70*2kg



FF17

Functional Trainer

Size:1525*1245*2170mm

Machine Weight:295kg

Weight Stack:70*2kg



FF18

Rotary Torso

Size:1355*1270*1500mm

Machine Weight:182.5kg

Weight Stack:70kg



FF19

Abdominal Machine

Size:1340*1290*1500mm

Machine Weight:194kg

Weight Stack:70kg



FF20

Split Shoulder Lifting Trainer

Size:1490*1270*1500mm

Machine Weight:211.5kg

Weight Stack:100kg



FF23

Leg Curl

Size:1485*1255*1500mm

Machine Weight:210kg

Weight Stack:70kg



FF24

Glute Isolator

Size:1360*980*1500mm

Machine Weight:191kg

Weight Stack:70kg

**FF25****Abductor/Adductor**

Size:1510*750*1500mm

Machine Weight:200.5kg

Weight Stack:70kg

**FF26****Seated Dip**

Size:1205*1150*1500mm

Machine Weight:204.5kg

Weight Stack:85kg

**FF28****45 Degree Triceps Extension**

Size:1130*1255*1500mm

Machine Weight:195kg

Weight Stack:70kg

**FF29****Split High Pull Trainer**

Size:1550*1200*2055mm

Machine Weight:232.5kg

Weight Stack:100kg

**FF30****45 Degree Camber Curl**

Size:1255*1250*1500mm

Machine Weight:181kg

Weight Stack:70kg

**FF31****Back Extension**

Size:1260*1085*1500mm

Machine Weight:206.5kg

Weight Stack:100kg

**FF33****Long Pull**

Size:1455*1175*1500mm

Machine Weight:177kg

Weight Stack:85kg

**FF34****Seated Row**

Size:1325*1270*1500mm

Machine Weight:216kg

Weight Stack:100kg



FF35

Pulldown

Size:1700*1475*1955mm
Machine Weight:254.5kg
Weight Stack:100kg



FF93

Seated Calf

Size:1330*1085*1500mm
Machine Weight:179.5kg
Weight Stack:70kg



FF85

Waist/Abdomen Trainer

Size:1120*1155*1500mm
Machine Weight:185.5kg



FF86

Biceps/Triceps

Size:1315*1185*1500mm
Machine Weight:193.5kg



FF87

Seated Leg Curl/Extension

Size:1255*1360*1500mm
Machine Weight:214.5kg



FF88

Chest/Shoulder Press

Size:1515*2235*1500mm
Machine Weight:261kg



FF89

Pull Down/ Long Pull

Size:2130*1230*2225mm
Machine Weight:215kg
Weight Stack:70kg



FF90

Prone Leg Curl/ Seated Extension

Size:1155*1530*1500mm
Machine Weight:206.5kg



FF94

Side Flat Lifting Chest Trainer

Size:1465*865*2005mm
Machine Weight:290kg



FF36

Flat Bench

Size:1280*740*380mm

Machine Weight:19.5kg



FF37

Adjustable Decline Bench

Size:1630*740*1075mm

Machine Weight:39kg



FF38

Multi-Purpose Bench

Size:1155*730*950mm

Machine Weight:22.5kg



FF39

Super Bench

Size:1330*740*515mm

Machine Weight:32kg



FF41

Olympic Decline Bench

Size:2235*1785*1270mm

Machine Weight:77kg



FF41B

Olympic Decline Bench

Size:2225*1705*1270mm

Machine Weight:77kg



FF42

Olympic Incline Bench

Size:1940*1785*1420mm

Machine Weight:76.5kg



FF42B

Olympic Incline Bench

Size:1925*1705*1415mm

Machine Weight:92kg



FF43

Olympic Flat Bench

Size:1740*1785*1280mm

Machine Weight:65kg



FF43B

Olympic Flat Bench

Size:1725*1705*1270mm

Machine Weight:82kg



FF44

Seated Preacher Curl

Size:925*935*900mm

Machine Weight:40.5kg



FF45

Roman Chair

Size:1100*750*790mm

Machine Weight:43kg



FF46

Multi Degree Olympic Bench

Size:2045*1250*1590mm

Machine Weight:53.5kg



FF47

Vekical Knee Up

Size:1140*785*1590mm

Machine Weight:73.5kg



FF48

Power Cage

Size:1315*1560*2290mm

Machine Weight:106kg



FF49

Two Layer Dumbbell Rack

Size:2230*750*755mm

Machine Weight:64kg



FF50

Squat Rack

Size:1690*1640*1840mm

Machine Weight:91.5kg



FF51

Olympic Seated Bench

Size:1640*1320*1770mm

Machine Weight:107kg



FF53

Handle Rack

Size:900*710*1060mm

Machine Weight:48kg



FF54

Weight Plate Tree

Size:600*620*1315mm

Machine Weight:23kg

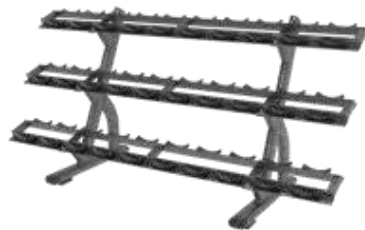

FF72

3 Layers Dumbbell Rack

Size:2230*780*1070mm

Machine Weight:89kg



FF55

Barbell Rack

Size:900*795*1500mm

Machine Weight:61kg



FF63

Smith Machine

Size:2175*1310*2320mm

Machine Weight:164.5kg

AN Series

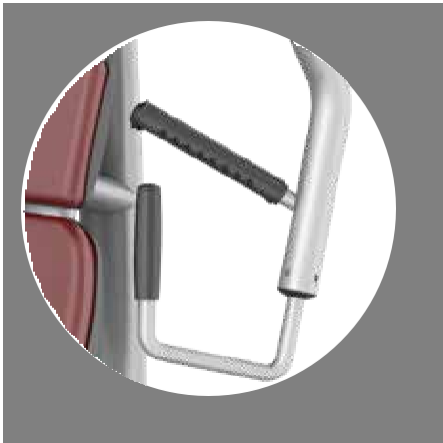

Round Steel Tube Wrapped By Rubber Handle, Good grasp feeling on muscle training



The weight can be increased or decreased according to user's own situation, the magnetic pull pin has good safety protection effect.



High Intensity Nylon Pulley, Elegant and Durable



Clear and concise muscle instruction picture help the user to know how to use the machine



AN04

Lat Pulldown
Size:1240*1210*2330mm
Machine Weight:224kg
Weight Stack:100kg



AN05

Pectoral Machine
Size:1350*1440*1500mm
Machine Weight:275kg
Weight Stack:100kg



AN06

Seated Horizontal Pully
Size:1790*1345*1830mm
Machine Weight:214kg
Weight Stack:100kg



AN09

Inner Thigh Adductor
Size:1185*1400*1500mm
Machine Weight:280kg
Weight Stack:70kg



AN10

Outer Thigh Abductor
Size:1345*860*1500mm
Machine Weight:280kg
Weight Stack:70kg



AN14

Cable Crossover
Size:3800*685*2395mm
Machine Weight:328kg
Weight Stack:70kg*2



AN15

Triceps Extension
Size:1045*1480*1480mm
Machine Weight:182kg
Weight Stack:70kg



AN16

Leg Press
Size:1985*1240*1815mm
Machine Weight:445kg
Weight Stack:100kg



AN18

Multi Hip

Size:1150*1215*1490mm

Machine Weight:290kg

Weight Stack:100kg



AN19

Lower Back

Size:1095*1275*1495mm

Machine Weight:255kg

Weight Stack:70kg



AN20

Chest Press

Size:1400*1345*1665mm

Machine Weight:252.5kg

Weight Stack:100kg



AN21

Pull Down

Size:1395*1395*1790mm

Machine Weight:262.5kg

Weight Stack:100kg



AN22

Total Abdominal

Size:1470*1610*2100mm

Machine Weight:227.5kg

Weight Stack:100kg



AN23

Upper Limbs

Size:1625*1440*2670mm

Machine Weight:350kg

Weight Stack:115kg



AN24

Seated Leg Curl

Size:1180*1530*1500mm

Machine Weight:235.5kg

Weight Stack:100kg



AN25

Arm Curl

Size:1000*1455*1500mm

Machine Weight:179kg

Weight Stack:70kg



AN26

Shoulder Press

Size:1415*940*1500mm

Machine Weight:232kg

Weight Stack:70kg



AN27

Leg Extension

Size:1175*1100*1500mm

Machine Weight:232.5kg

Weight Stack:100kg



AN30

Abdominal Machine

Size:1060*1355*1500mm

Machine Weight:255kg

Weight Stack:100kg



AN32

Pull Down

Size:860*1300*1915mm

Machine Weight:300kg

Weight Stack:100kg



AN33

Seated Row

Size:1025*1195*1500mm

Machine Weight:255kg

Weight Stack:100kg



AN34

Delt Machine

Size:1155*1285*1500mm

Machine Weight:280kg

Weight Stack:100kg



AN35

Rotary Torso

Size:1085*1225*1500mm

Machine Weight:270kg

Weight Stack:70kg



AN36

Glute Isolator

Size:1200*1335*1810mm

Machine Weight:290kg

Weight Stack:70kg



AN37

Horizontal Leg Curl

Size:1718*1100*1500mm

Machine Weight:265kg

Weight Stack:100kg



AN38

Pearl Delt /Pec Fly

Size:855*1165*2100mm

Machine Weight:220.5kg

Weight Stack:100kg



AN46

Biceps Curl

Size:1295*1020*1490mm

Machine Weight:164.5kg

Weight Stack:70kg



AN47

Chest Incline

Size:1500*1130*1505mm

Machine Weight:300kg

Weight Stack:100kg



AN48

Standing Calf

Size:1145*1030*1660mm

Machine Weight:220kg

Weight Stack:100kg



AN49

Triceps Dip

Size:1245*1160*1480mm

Machine Weight:199kg

Weight Stack:70kg



AN54

Functional Trainer

Size:2055*1265*2420mm

Machine Weight:344kg

Weight Stack:70kg*2



AN74

Standing Rear Delt

Size:1200*900*1855mm

Machine Weight:243kg

Weight Stack:70kg



AN01

Weight Plate Tree
Size:660*740*825mm
Machine Weight:28kg



AN02

Dumbbell Rack
Size:2410*560*880mm
Machine Weight:61kg



AN03

Barbell Rack
Size:885*690*1300mm
Machine Weight:90kg



AN07

Adjustable Web Board
Size:1520*665*945mm
Machine Weight:42.5kg



AN08

Flat Bench
Size:1185*570*550mm
Machine Weight:35kg



AN12

Multi Adjustable Bench
Size:1215*565*480mm
Machine Weight:31.5kg



AN13

Scott Bench
Size:1010*800*915mm
Machine Weight:42kg



AN17

Smith Machine
Size:2200*2070*2500mm
Machine Weight:233kg



AN28

Vekical Bench

Size:1245*1645*1870mm

Machine Weight:74kg



AN31

Roman Chair

Size:1295*675*790mm

Machine Weight:34kg



AN73

Adjustable Roman Chair

Size:1400*675*950mm

Machine Weight:42kg



AN40

Utility Bench

Size:1070*630*910mm

Machine Weight:23.5kg



AN44

Decline Bench (Luxury)

Size:2225*1620*1360mm

Machine Weight:89.5kg



AN50

Squat Rack

Size:1675*1520*1810mm

Machine Weight:98.5kg



AN52

Olympic Flat Bench

Size:1625*1855*1290mm

Machine Weight:82.5kg



AN55

Hack Squat

Size:2090*1650*1290mm

Machine Weight:170kg



AN56

Leg Press

Size:2340*1460*1670mm

Machine Weight:230kg



AN57

Web Board

Size:1795*615*950mm

Machine Weight:36kg



AN58

Vekical Knee Chin/Up

Size:1500*1305*2310mm

Machine Weight:66.5kg



AN59

Incline Bench (Luxury)

Size:2100*1640*1540mm

Machine Weight:106.5kg



AN61

Barbell Rack for 10pcs

Size:1065*870*1480mm

Machine Weight:71.5kg

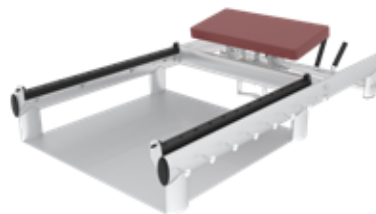

AN65-(1)

Hip Machine

Size:1960*1190*460mm

Machine Weight:110kg



AN65-(2)

Hip Machine

Size:1960*1190*460mm

Machine Weight:130kg



AN70

T Incline Rower Machine

Size:2305*830*835mm

Machine Weight:58kg





AN72

3 Layers Dumbbell Rack

Size:2450*950*970mm

Machine Weight:85kg



AN75

Knee Up/Chin+Pull Up

Size:1455*1360*2235mm

Machine Weight:208kg



AN17A

Customized Smith Machine

Size:2200*2450*2490mm

Machine Weight:400kg

AN41

Crossover & Cable Jungle (5 stations)

Size:4615*1920*2395mm

Machine Weight:680kg

Weight Stack:70kg*4

100kg*1

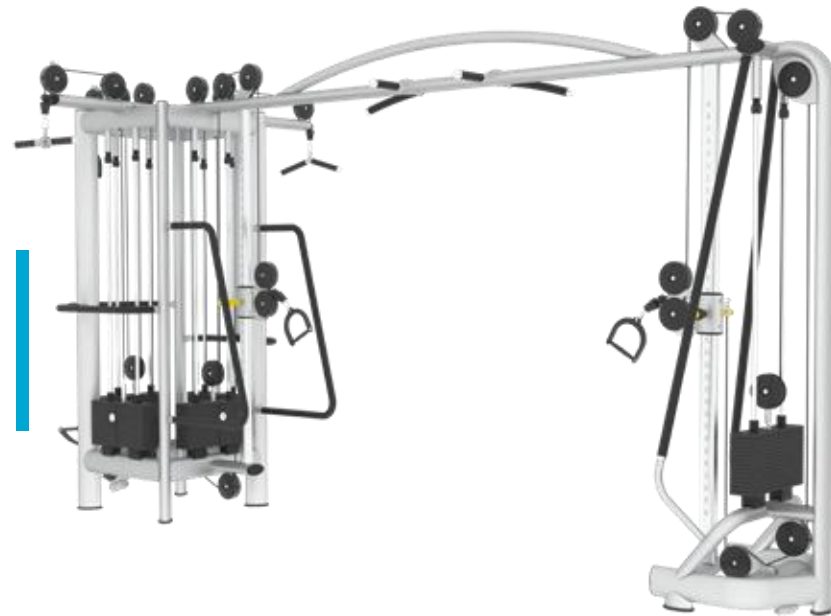



AN60

8 Station

Size:6620*3070*2400mm

Machine Weight:1100kg

Weight Stack:70kg*4

100kg*4

AN43

Multi Station

Size:1925*1915*2375mm

Machine Weight:510kg

Weight Stack:70kg*3

100kg*1



AN42

Crossover & Cable Jungle (customized 5 stations)

Size:5545*2785*2705mm

Machine Weight:790kg

Weight Stack:70kg*2

115kg*1

100kg*2



F Series



Instruction

Clear and concise muscle target makes it easier for trainers to know and learn.

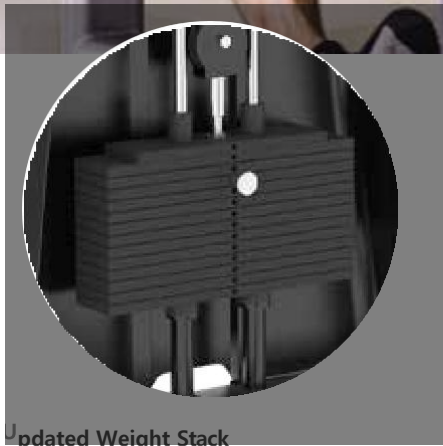

Updated Weight Stack

The weight can be increased or decreased according to trainer's own situation, and the magnetic pull pin has good safety protection effect.

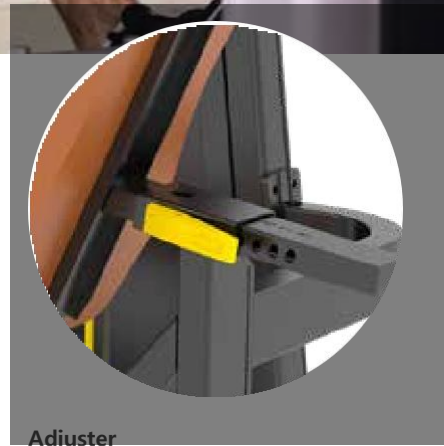

Adjuster

Humanization Design Adjustment. Trainers can adjust the position according to personal body condition

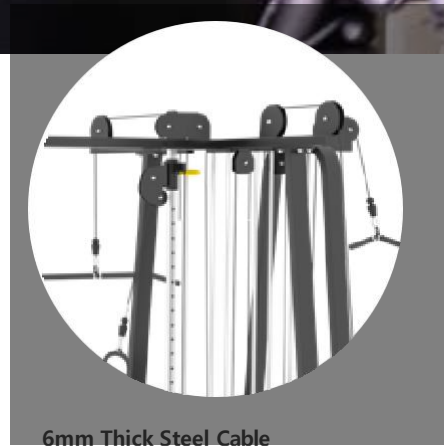

6mm Thick Steel Cable

Fitness equipment uses 6mm thick steel cable, which is more durable and safer.

**F01****Prone Leg Curl**

Size:1645*940*1630mm

Machine Weight:179.5kg

Weight Stack:70kg

**F02****Leg Extension**

Size:1395*990*1630mm

Machine Weight:186.5kg

Weight Stack:70kg

**F03****Leg Press**

Size:1960*1040*1630mm

Machine Weight:223kg

Weight Stack:100kg

**F04****Butterfly**

Size:1485*855*1630mm

Machine Weight:223kg

Weight Stack:70kg

**F05****Lateral Raise**

Size:1255*825*1630mm

Machine Weight:169.5kg

Weight Stack:70kg

**F06****Incline Shoulder Press**

Size:1885*1320*1630mm

Machine Weight:239kg

Weight Stack:70kg

**F07****Pearl Delt/Pec Fly**

Size:1170*850*2030mm

Machine Weight:260kg

Weight Stack:100kg

**F08****Vekical Press**

Size:1380*1315*1630mm

Machine Weight:193kg

Weight Stack:70kg



F09

Dip/Chin Assist

Size:1400*1135*2345mm

Machine Weight:290.5kg

Weight Stack:100kg



F11

Multi Hip

Size:1295*1055*1630mm

Machine Weight:239kg

Weight Stack:70kg



F13

Incline Chest Press

Size:2160*1430*1630mm

Machine Weight:239kg

Weight Stack:70kg



F16

Adjustable Crossover

Size:3815*685*2280mm

Machine Weight:299kg

Weight Stack:70kg*2



F17

FTS Glide

Size:1885*1000*2295mm

Machine Weight:320.5kg

Weight Stack:70kg*2



F18

Rotary Torso

Size:1115*1055*1630mm

Machine Weight:175kg

Weight Stack:70kg



F19

Abdominal Isolator

Size:1255*940*1630mm

Machine Weight:209kg

Weight Stack:70kg



F20

Seated Shoulder Press

Size:1895*1435*1630mm

Machine Weight:232.5kg

Weight Stack:70kg

**F21****Abductor A**

Size:1550*890*1630mm

Machine Weight:214kg

Weight Stack:70kg

**F22****Adductor B**

Size:1550*890*1630mm

Machine Weight:214kg

Weight Stack:70kg

**F23****Leg Curl**

Size:1610*990*1630mm

Machine Weight:223kg

Weight Stack:70kg

**F24****Glute Isolator**

Size:1185*1070*1630mm

Machine Weight:141kg

Weight Stack:70kg

**F25****Abductor / Adductor**

Size:1545*900*1630mm

Machine Weight:221.5kg

Weight Stack:70kg

**F26****Seated Dip**

Size:1600*1190*1630mm

Machine Weight:230kg

Weight Stack:70kg

**F28****45 Degree Triceps Extension**

Size:1115*930*1630mm

Machine Weight:190kg

Weight Stack:70kg

**F30****45 Degree Camber Curl**

Size:1225*920*1630mm

Machine Weight:167kg

Weight Stack:70kg



F31

Back Extension

Size:1225*970*1630mm

Machine Weight:194.5kg

Weight Stack:70kg



F33

Long Pull

Size:1655*1300*2040mm

Machine Weight:268kg

Weight Stack:100kg



F34

Vekical Row

Size:1570*1205*1630mm

Machine Weight:194kg

Weight Stack:70kg



F35

Pulldown

Size:1235*1175*2230mm

Machine Weight:213kg

Weight Stack:100kg



F85B

Abdominal / Back Extension

Size:995*1195*1630mm

Machine Weight:198kg

Weight Stack:70kg



F86B

Biceps / Triceps

Size:980*1220*1630mm

Machine Weight:182kg

Weight Stack:70kg



F87B

Leg Extension / Curl

Size:975*1420*1630mm

Machine Weight:193.5kg

Weight Stack:70kg



F88

Chest / Shoulder Press

Size:2000*1325*1630mm

Machine Weight:245.5kg

Weight Stack:70kg

**F89****Pull Down/ Long Pull**

Size:2040*1210*2330mm

Machine Weight:214kg

Weight Stack:70kg

**F90****Prone Leg Curl /
Leg Extension**

Size:1860*965*1630mm

Machine Weight:187.5kg

Weight Stack:70kg

**F95****Standing Rear Dearth/
Pec Fly**

Size:765*1525*1650mm

Machine Weight:174.5kg

Weight Stack:70kg

**F97****Forearm Trainer**

Size:750*265*860mm

Machine Weight:125kg

Weight Stack:100kg

**F14****Rotary Rack**

Size:1270*695*1290mm

Machine Weight:65kg

**F36****Flat Bench**

Size:1410*560*430mm

Machine Weight:23kg

**F37****Adjustable Decline Bench**

Size:1710*680*850mm

Machine Weight:46kg

**F38****Multi-Purpose Bench**

Size:1180*675*945mm

Machine Weight:21.5kg



F39

Super Bench

Size:1400*665*520mm

Machine Weight:37kg



F41

Olympic Decline Bench

Size:2055*1655*1235mm

Machine Weight:72kg



F42

Olympic Bench Incline

Size:2030*1780*1500mm

Machine Weight:92kg



F43

Olympic Bench

Size:1785*1775*1225mm

Machine Weight:58kg



F44

Seated Preacher Curl

Size:1120*775*905mm

Machine Weight:43.5kg



F45

Back Extension

Size:1085*790*765mm

Machine Weight:43.5kg



F46

Hip Thruster

Size:1540*1360*780mm

Machine Weight:83.5kg



F47

Vekical Knee Up/Dip

Size:1175*815*1615mm

Machine Weight:96kg

**F48****Power Cage**

Size:1320*1485*2295mm

Machine Weight:125.5kg

**F49****Dumbbell Rack**

Size:2480*750*720mm

Machine Weight:64kg

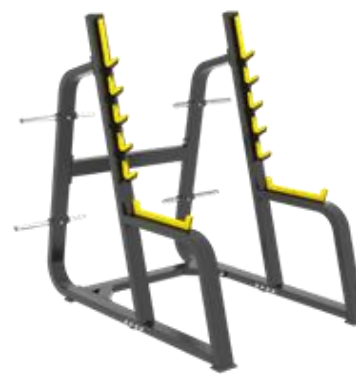
**F50****Squat Rack**

Size:1710*1690*1800mm

Machine Weight:108.5kg

**F51****Olympic Seated Bench**

Size:1775*1530*1770mm

Machine Weight:135kg

**F53****Handle Rack**

Size:1090*740*1070mm

Machine Weight:68kg

**F54****Vekical Plate Tree**

Size:630*540*1270mm

Machine Weight:25kg

**F55****Barbell Rack**

Size:1050*790*1460mm

Machine Weight:71kg

**F56****Leg Press**

Size:2180*1650*1350mm

Machine Weight:220kg



F57

Hack Slide

Size:2250*1650*1275mm

Machine Weight:194kg



F58

Leg Press & Hack Slide

Size:2260*1690*1430mm

Machine Weight:325kg



F61

Incline Level Row

Size:1735*1110*1175mm

Machine Weight:66kg



F62

Seated Calf

Size:1465*640*1015mm

Machine Weight:54kg



F63

Smith Machine

Size:2210*1400*2435mm

Machine Weight:290kg



F65

Super Squat

Size:1985*1650*1415mm

Machine Weight:150kg



F65B

Super Squat

Size:1985*1560*1760mm

Machine Weight:150kg



F70

Abdominal Trainer

Size:1530*930*1040mm

Machine Weight:60.5kg



F71

Stretch Trainer

Size:1290*530*1090mm

Machine Weight:80kg



F72

Beauty Dumbbell Rack

Size:1440*705*1005mm

Machine Weight:70.5kg



F73

**Three-tier
Dumbbell Rack**

Size:1320*575*870mm



F80

Knee Up Chin + Pull Up

Size:1360*1465*2230mm

Machine Weight:115kg



F84

Squat Lunge

Size:1720*1500*845mm

Machine Weight:200kg



F92

Sled

Size:870*650*1115mm

Machine Weight:54kg



F94

Glute Ham Raise Bench

Size:1640*810*1035mm

Machine Weight:84kg



F96

**Dual Function
Preacher Curl**

Size:1245*725*1070mm

Machine Weight:83kg



F98

Adjustable Bench

Size:1495*710*1120mm

Machine Weight:63.5kg



F99

Adjustable Incline Flat Bench

Size:1290*570*475mm

Machine Weight:24kg



F101

Reverse Hyper Extension

Size:2300*1100*780mm

Machine Weight:60kg

F64

8 Multi Station

Size:5130*4740*2350mm

Machine Weight:1100kg

Weight Stack:56kg*2

68kg*3

100kg*3

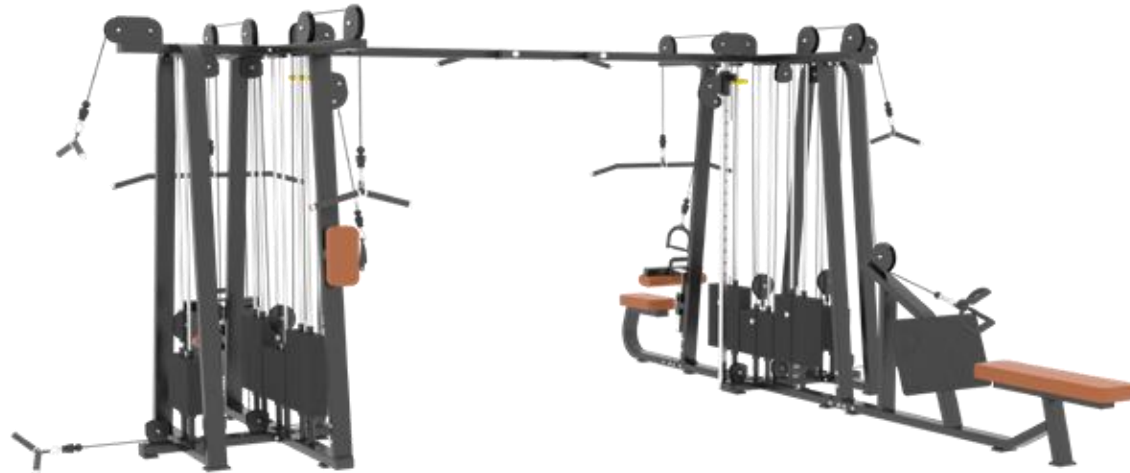

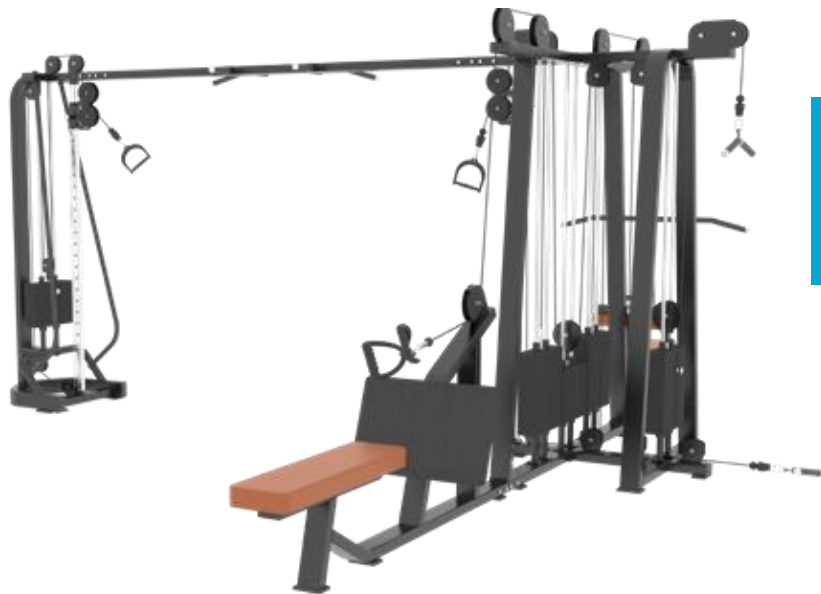

F81

5 Multi Station (Half F64 & half F16)

Size:4895*4605*2345mm

Machine Weight:860kg

Weight Stack:56kg*2

68kg*1

100kg*2

F82

4 Multi Station

Size:4605*1415*2345mm

Machine Weight:600kg

Weight Stack:56kg*1

68kg*1

100kg*2



F83

8 Multi Station

Size:5170*4605*2345mm

Machine Weight:1300kg

Weight Stack:56kg*2

68kg*2

100kg*4

PL Series



Grip

Non-slip grip length is reasonable ,angle is scientific,anti-slip effect is obvious.

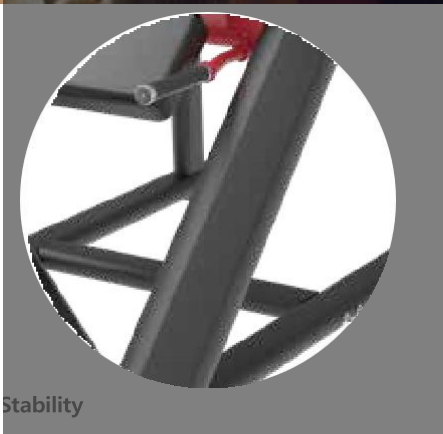

Stability

Flat elliptical tube steel frame ,safe and reliable ,never deformed.

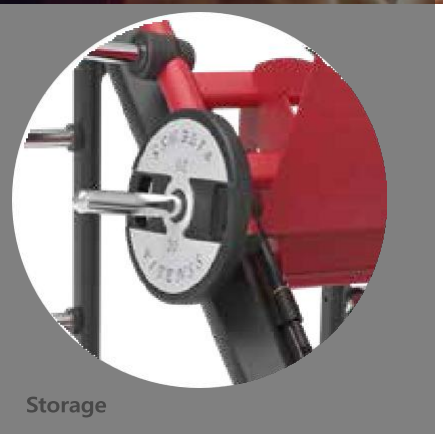

Storage

Comes with weight plate storage bar and functional devices,Storage location for easy use.

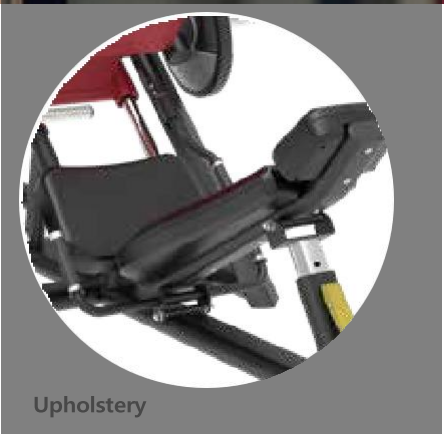

Upholstery

Designed according to ergonomic principles,high-quality PU finishes,the seat can be adjusted in multiple levels,So that exerciser of different sizes can find a suitable exercise method.



PL01

Chest Press

Size:1925*1040*1745mm

Machine Weight:145.5kg



PL02

Incline Press

Size:1940*1400*1800mm

Machine Weight:120.5kg



PL03

Shoulder Press

Size:1530*1475*1500mm

Machine Weight:112kg



PL04

Seated Dip

Size:1975*1015*1005mm

Machine Weight:116kg



PL05

Biceps Curl

Size:1475*925*1265mm

Machine Weight:97kg



PL06

Pulldown

Size:1825*1455*2040mm

Machine Weight:126.5kg



PL07

Low Row

Size:1680*1310*1700mm

Machine Weight:117kg



PL08

Rowing

Size:1455*1385*1270mm

Machine Weight:114kg



PL09

Leg Curl

Size:1540*1275*1370mm

Machine Weight:115kg



PL10

Leg Extension

Size:1850*1530*1210mm

Machine Weight:112.5kg



PL11

Standing / Seated Shrug

Size:1630*1155*1160mm

Machine Weight:106kg



PL12

Iso-lateral Horizontal Bench Press

Size:1915*1750*1010mm

Machine Weight:109.5kg



PL13

Super Incline Chest Press

Size:1700*1315*1545mm

Machine Weight:130kg



PL14

Decline Chest Press

Size:1755*1130*1805mm

Machine Weight:129kg



PL15

Wide Chest Press

Size:1920*1270*1845mm

Machine Weight:145.5kg



PL16

Iso-Lateral Chest Press / Pulldown

Size:1915*1675*2120mm

Machine Weight:172kg



PL17

Iso-Lateral Front Lat Pulldown

Size:1670*1615*2080mm

Machine Weight:141kg



PL18

D.Y Row

Size:1630*1390*2050mm

Machine Weight:147kg



PL19

Gripper

Size:1230*660*940mm

Machine Weight:47kg



PL20

Abdominal Oblique Crunch

Size:1485*1200*1700mm

Machine Weight:126kg



PL21

Iso-Lateral Leg Curl

Size:1755*1320*940mm

Machine Weight:92.5kg



PL22

Iso-Lateral Leg Press

Size:1890*1198*1430mm

Machine Weight:190.5kg



PL23

Tibia Dorsi Flexion

Size:1110*345*345mm

Machine Weight:25kg



PL24

Hip Builder

Size:1575*1625*1420mm

Machine Weight:168kg



PL25
Side Arm Lifting Trainer
Size:1235*1375*1265mm
Machine Weight:89.5kg



PL26
Arm Press Back
Size:1725*1865*1475mm
Machine Weight:134kg



PL27
Standing Calf
Size:1270*1455*1565mm
Machine Weight:89kg



PL28
Shoulder Press
Size:1120*1856*1745mm
Machine Weight:99.5kg



PL29
Abductor
Size:1750*1185*1185mm
Machine Weight:108.5kg



PL30
Adductor
Size:1680*1180*1170mm
Machine Weight:109kg



PL31
V- Squat
Size:2015*1610*1650mm
Machine Weight:152kg



PL32
Abdominal Trainer
Size:1100*520*485mm
Machine Weight:30kg



PL33

Decline Chest Press

Size:2155*1785*1025mm

Machine Weight:119kg



PL34

Seated Leg Curl

Size:1600*1455*1255mm

Machine Weight:112kg



PL35

Abdominal & Knee Up/Dip

Size:2545*770*1720mm

Machine Weight:102.5kg



PL36

Lat Pulldown

Size:1655*1415*2085mm

Machine Weight:135kg



PL37

Multi-angle Chest Push Trainer

Size:2080*2100*2075mm

Machine Weight:251kg



PL38

Squat Machine

Size:1915*990*1935mm

Machine Weight:122kg



PL39

Bent-Over Row

Size:1735*1660*1245mm

Machine Weight:189kg



PL40

Glute Builder

Size:1845*1680*1245mm

Machine Weight:145kg



PL42
3D Multi Angle Hip Abduction Trainer
Size:1805*960*1405mm



PL43
Pendulum Style Back Kick Trainer
Size:1515*1295*1400mm



PL44
Kneeling Hip Punch Trainer
Size:1770*1315*1510mm



PL45
Dual Directional 45 Degree Extension
Size:1545*1131*1155mm



PL56
Linear Leg Press
Size:2425*1415*1505mm
Machine Weight:244kg



PL57
Linear Hack Squat
Size:2180*1610*1500mm
Machine Weight:184.5kg



PL61
Incline Lever Row
Size:1845*1330*1155mm
Machine Weight:70kg



PL62
Calf Raise
Size:1455*740*1045mm
Machine Weight:53.5kg



PL65
Squat
 Size:2285*1760*1565mm
 Machine Weight:218.5kg



PL66
Standing Press
 Size:2080*1550*2105mm
 Machine Weight:134kg



PL67
Standing Incline Press
 Size:1945*1915*1925mm
 Machine Weight:132.5kg



PL68
Standing Decline Press
 Size:1890*1440*2560mm
 Machine Weight:145kg



PL69
Squat Lunge
 Size:1600*1525*790mm
 Machine Weight:96.5kg



PL73B
Hip Thrust Machine
 Size:1765*1650*840mm
 Machine Weight:100.5kg



PL74
Hip Belt Squat Machine
 Size:1810*1380*1150mm
 Machine Weight:143.5kg



PL75
Incline Chest Fly Machine
 Size:1545*1470*1090mm
 Machine Weight:65kg



PL76
Vekical Leg Press
 Size:1505*1335*1900mm
 Machine Weight:165kg

G Series

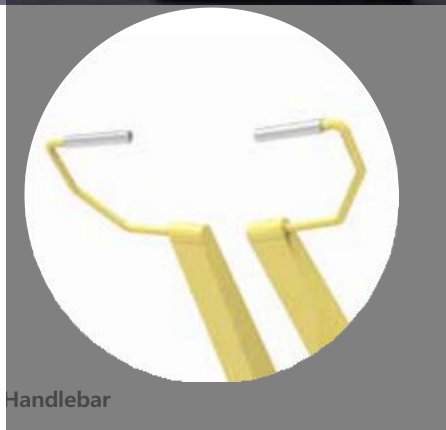

Handlebar

The length of the aluminum alloy handlebar is reasonable, the angle is scientific, and the anti-slip effect is obvious.

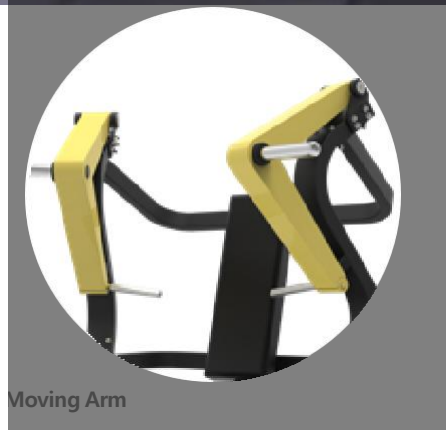

Moving Arm

Bold yellow moving arm highlights the entire series, with bright yellow and black main frame for perfect color matching

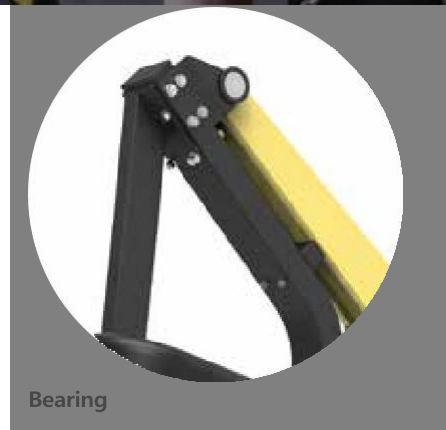

Bearing

Steel shaft bearing, aluminum bearing cap, no noise during movement, no resistance, durable.

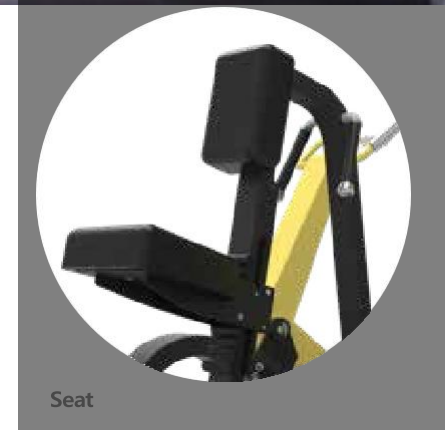

Seat

Designed according to ergonomic principles, high-quality PU leather, the seat can be adjusted in multiple steps, so that different body types of athletes can find their own exercise posture.

**G05****Chest Press**

Size:1720*1395*1720mm

Machine Weight:165kg

**G10****Wide Chest Press**

Size:1270*1525*1775mm

Machine Weight:165kg

**G15****Incline Chest Press**

Size:1550*1040*1665mm

Machine Weight:163kg

**G20****Pulldown**

Size:1750*1275*1995mm

Machine Weight:152kg

**G25****Low Row**

Size:1310*1280*1630mm

Machine Weight:135.5kg

**G30****Incline Level Row**

Size:1430*1195*1295mm

Machine Weight:125.5kg

**G35****Shoulder Press**

Size:1180*1300*1500mm

Machine Weight:130kg

**G40****Rear Kick**

Size:1490*1130*1685mm

Machine Weight:120.5kg



G45

Calf

Size:1715*1190*1210mm

Machine Weight:198kg



G50

Leg Press

Size:2040*1460*1405mm

Machine Weight:264kg



G55

Leg Extension

Size:1545*1340*1015mm

Machine Weight:98.5kg



G60

Seated Dip

Size:1670*1550*1110mm

Machine Weight:160kg



G65

Biceps

Size:1180*1585*985mm

Machine Weight:150kg



G70

Standing Leg Curl

Size:1415*1120*1295mm

Machine Weight:120kg



G75

Linear Leg Press

Size:2750*1700*1490mm

Machine Weight:340kg

H Series



Steel Pipe

Stable, durable and not easy to rust

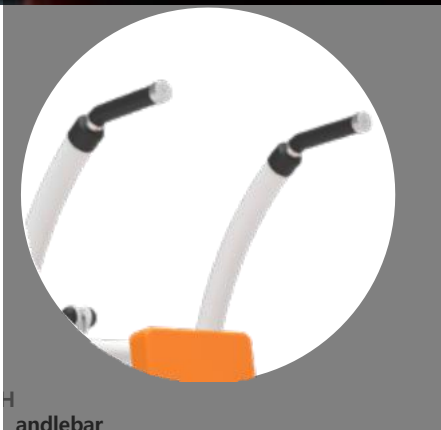

Handlebar

The handlebar the non-slip handle make it easy for the exerciser to adjust to the proper posture ,which makes the referral training more suitable.



Hydraulic Cylinder

Six different gears provide different resistance to the trainer, allowing different trainers to find the right way to exercise.



Seat

Designed according to ergonomics, high quality PU leather. The seat can be adjusted in multiple steps,so that different body types of athletes can find a suitable posture for themselves.

H series commercial hydraulic cylinder cycle trainer is a series of strength training equipment. The H-series is ideal for fitness, slimming and improving health, and offers fitness enthusiasts a different fitness style than traditional gym training. The H cycle training equipment conveys the fluid energy of the hydraulic cylinder into a linear motion of reciprocating push or pull in the cylinder, and the movement is smoother and simpler. Each model exercises a training session and a series is a professional fitness mode. Safe to use, less to sports injuries, create a harmonious training atmosphere for trainers, especially for middle-aged and older trainers. The hydraulic cylinder can adjust different resistances, and the trainer sets the appropriate gear position. This series uses high-grade aluminum alloy hydraulic cylinders. The installation design of hydraulic cylinders is safe and reliable, and the spoke mode conforms to the human body simulation exercise track. Easy to move to suit the needs of the site, aluminum joints are used for each joint, and cushions and cushions use environmentally friendly materials.



H01

Chest press

Size:970*700*1300mm

Machine Weight:43kg



H02

Pec Fly/Rear Deltoid

Size:970*840*1270mm

Machine Weight:43.5kg



H03

Overhead Press / Pulldown

Size:970*700*1645mm

Machine Weight:45.5kg



H04

Biceps Curl/ Triceps Extension

Size:1140*690*880mm

Machine Weight:33kg



H05

Leg Extension / Leg Curl

Size:1395*744*1340mm

Machine Weight:47kg



H06

Hip Abductor/Adductor

Size:1340*950*1305mm

Machine Weight:50kg



H07

Leg press

Size:1595*650*1555mm

Machine Weight:54kg



H08

Squat

Size:1410*700*1195mm

Machine Weight:46kg



H09

**Abdominal Crunch/
Back Extension**

Size:1210*800*1075mm

Machine Weight:40.5kg



H10

Rotary Torso

Size:1015*930*935mm

Machine Weight:43kg



H11

Glute Isolator

Size:1240*945*1175mm

Machine Weight:68kg



H12

Shoulder Lift Trainer

Size:770*900*1125mm

Machine Weight:45.5kg

HA Series



HA01

ISO Lateral Incline Press
Size:1435*1666*1978mm
Machine Weight:139kg

HA02

ISO Lateral High Row
Size:1837*1620*2000mm
Machine Weight:149kg

HA03

ISO Lateral Leg Press
Size:1989*1770*1544mm
Machine Weight:148kg

HA04

ISO Wide Chest Press
Size:1323*1600*1746mm
Machine Weight:140kg



HA05

ISO Seated Chest Press & Lat Pulldown
 Size:1850*1770*2000mm
 Machine Weight:160kg



HA06

ISO Lateral Rowing
 Size:1558*1426*1467mm
 Machine Weight:128kg



HA07

ISO Lateral Wide Chest
 Size:1313*1980*1760mm
 Machine Weight:141kg



HA08

Squat Lunge
 Size:1358*1617*873mm
 Machine Weight:100kg



HA09

Smith Machine
 Size:1340*2266*2384mm
 Machine Weight:215kg



HA10

Olympic Military Bench
 Size:1763*1210*1670mm
 Machine Weight:88kg



HA13

ISO Lateral DY Rowing
 Size:1455*1476*2133mm
 Machine Weight:135kg



HA14

Weight Plate Tree
 Size:710*610*1025mm
 Machine Weight:37kg



HA15

ISO Lateral Super Incline Press

Size:1500*1350*1650mm
Machine Weight:137kg



HA16

ISO Lateral Lat Pulldown

Size:1650*1100*2050mm
Machine Weight:145kg



HA17

ISO Lateral Leg Extension

Size:1433*1477*1470mm
Machine Weight:126kg



HA18

ISO Lateral Prone Leg Curl

Size:1550*1300*800mm
Machine Weight:128kg



HA19

45 Degree Leg Press

Size:2350*1855*1500mm
Machine Weight:251kg



HA20

Seated Arm Curl

Size:1000*800*1120mm
Machine Weight:72kg



HA21

ISO Lateral Shoulder Press

Size:1500*1250*1900mm
Machine Weight:139kg



HA22

Squat High Pull

Size:1650*1150*1051mm
Machine Weight:99kg



HA23

Seated Calf Raise

Size:1230*730*1004mm

Machine Weight:65kg



HA24

Seated Calf

Size:1673*1630*1500mm

Machine Weight:135kg



HA25

ISO Lateral Low Row

Size:1250*1056*1700mm

Machine Weight:139kg



HA26

ISO Deline Chest Press

Size:1300*1150*1750mm

Machine Weight:141kg



HA27

**ISO Lateral Wide
Lat Pulldown**

Size:1800*1100*2150mm

Machine Weight:141kg



HA28

ISO Laydown Chest Press

Size:1700*1400*1200mm

Machine Weight:112kg



HA29

Seated Biceps

Size:1466*1292*1502mm

Machine Weight:93kg



HA30

Standing Press

Size:2092*1790*2252mm

Machine Weight:142kg



HA31

Olympic Squat Rack

Size:1763*1210*1670mm

Machine Weight:88kg



HA34

Flat Bench

Size:1295*595*457mm

Machine Weight:23kg



HA35

Tension Machine

Size:1545*1350*1710mm

Machine Weight:130kg



HA36

Gripper

Size:1075*580*855mm

Machine Weight:53kg



HA37

Seated Leg Extension

Size:1440*1695*1480mm

Machine Weight:104kg



HA38

Olympic Flat Bench

Size:2000*1150*1150mm

Machine Weight:78kg



HA40

Adjustable Bench

Size:1380*664*455mm

Machine Weight:40kg



HA41

Tibia Dorsi Flexion

Size:950*380*336mm

Machine Weight:27kg



HA42

Olympic Incline Bench
 Size:1400*1286*1600mm
 Machine Weight:69kg



HA45

Adjustable Abdominal Bench
 Size:1215*680*1070mm
 Machine Weight:40kg



HA46

Multi-functional Bench
 Size:2070*1180*1270mm
 Machine Weight:95kg



HA48

ISO-Lateral Rear Deltoid
 Size:1920*1050*880mm
 Machine Weight:90kg



HA49

Fore Arm
 Size:750*1110*445mm
 Machine Weight:65kg



HA50

Dumbbell Rack
 Size:2105*590*780mm
 Machine Weight:58kg



HA51

75 Degree Utility
 Size:1120*640*1145mm
 Machine Weight:28kg



HA52

Flat Bench
 Size:1270*470*430mm
 Machine Weight:55kg



HA55

Adjustable Decline Bench

Size:1400*680*600mm

Machine Weight:48kg



HA56

Incline Pec Fly

Size:1350*1650*1350mm

Machine Weight:92kg



HA58

Lateral Raise

Size:1050*1506*1300mm

Machine Weight:102kg



HA59

Abductor

Size:1690*730*750mm

Machine Weight:139kg



HA61

Barbell Rack

Size:780*620*1450mm

Machine Weight:80kg



HA63

4 Way Neck

Size:900*1400*1600mm

Machine Weight:130kg



HA64

Comprehensive Incline

Size:1800*1650*1830mm

Machine Weight:138kg



HA65

Comprehensive Decline

Size:1650*1300*2440mm

Machine Weight:163kg



HA66

ISO Lateral Knee Leg Curl

Size:1270*1000*1290mm

Machine Weight:145kg



HA67

Seated Dip

Size:1710*970*1070mm

Machine Weight:130kg



HA68

Pull Over

Size:1231*1360*1503mm

Machine Weight:120kg



HA70

Adductor

Size:1690*730*750mm

Machine Weight:139kg



HA71

V-Squat

Size:2430*1450*1810mm

Machine Weight:242kg



HA72

Abdominal

Size:1670*1100*1600mm

Machine Weight:121kg



HA73

Olympic Decline Bench

Size:1500*1150*1280mm

Machine Weight:65kg



HA80

Stand Calf

Size:1200*1208*1503mm

Machine Weight:124kg



HA82

Strength Hip and Glute

Size:1250*1750*1090mm

Machine Weight:65kg



HA83

Seated Triceps Extension

Size:1355*1330*1410mm

Machine Weight:90kg



HA84

Abdominal Trainer

Size:980*485*540mm

Machine Weight:34kg



HA85

Barbell Rack

Size:940*820*1510mm

Machine Weight:72kg



HA86

Adjustable Bench

Size:1760*670*485mm

Machine Weight:39kg



HA88

Back Extension

Size:1552*770*876mm

Machine Weight:42kg



HA89

Vekical Leg Press

Size:1300*1050*1800mm

Machine Weight:122kg



HA90

T Level Row

Size:2296*1136*920mm

Machine Weight:76kg



HA93

Decline Chest Press

Size:1730*2070*1110mm

Machine Weight:90kg



HA95

Fixed Pad Glute

Size:1830*840*1270mm

Machine Weight:150kg



HA96

Linear Hack Press

Size:2350*1855*1500mm

Machine Weight:251kg



HA97

Olympic Power Rack & Pull Up

Size:1785*1365*2235mm

Machine Weight:165kg



HA98

Seated Leg Curl

Size:1440*1695*1484mm

Machine Weight:103kg



HA103

Adjustable Bench

Size:1470*550*420mm

Machine Weight:40kg



HA116

Shoulder Lifting Machine

Size:1358*980*1445mm

Machine Weight:83kg



HA117

Shoulder Double Sided Lifting Machine

Size:1358*980*1445mm

Machine Weight:83kg

E360 Series Multifunctional Power Rack

More training areas, can carry out a number of distinctive fitness exercises, allowing customers to get a more comprehensive fitness effect, the functional training area has multiple elements, including physical combat, bounce, pull-ups, spoks belt functional training, core stability training, team training, strength training, balance, endurance, speed, flexibility, etc.

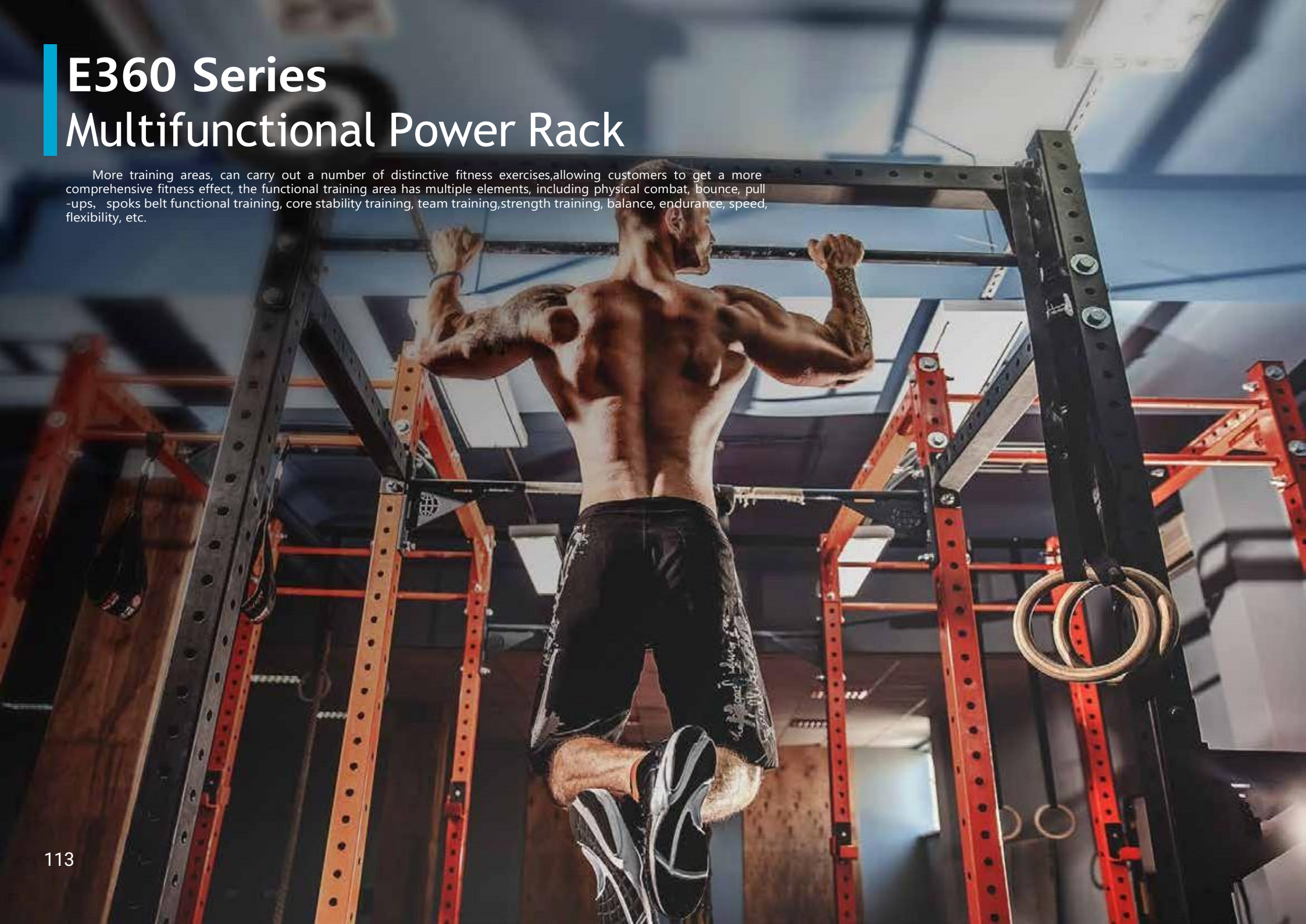



E360-A

Synergy 360(8 gates) with whole set of accessories

Accessories: Rope:4pcs
 Climbing rope:1pc
 Small trampoing:1 pc
 Boxing bag:1pc
 Olympic bar:1pc
 Kettle-bell:1set
 Medicin ball:1set

Size(L*W* H):8330*5630*2550mm

E360-B

Synergy 360(6 gates) with whole set of accessories

Accessories: Rope:4pcs
 Climbing rope:1pc
 Small trampoing:1 pc
 Boxing bag:1pc
 Olympic bar:1pc
 Kettle-bell:1set
 Medicin ball:1set

Size(L*W* H):4430*4025*2550mm





E360-E

Synergy 360(4 gates) with whole set of accessories

Accessories: Rope:2pcs
Climbing rope:1pc
Small trampoing:1 pc
Boxing bag:1pc
Olympic bar:1pc
Kettle-bell:1set
Medicin ball:1set

Size(L*W* H):3530*3160*2345mm

E360-F

Synergy 360(4 gates)
with whole set of accessories

Accessories: Rope:2pcs
Climbing rope:1pc
Small trampoing:1 pc
Boxing bag:1pc
Olympic bar:1pc
Kettle-bell:1set
Medicin ball:1set

Size(L*W* H):5065*2955*2345mm



E360-K

Synergy 360 (6 Stations + 1 Smith Machine) + whole set of accessories

Accessories: Rope:2pcs
Climbing rope:1pc
Small trampoing:1 pc
Boxing bag:1pc
Olympic bar:1pc
Kettle-bell:1set
Medicin ball:1set

Size(L*W* H):5070*4150*2410mm



C Series





C83B

Adjustable Dumbbell
 Size:430*210*210mm
 Professional Training
 Machine Weight:25kg



C73A

**Adjustable Dumbbell
 (1Pair+Bracket)**
 Size:340*270*125mm
 Machine Weight:15kg



C73B

**Adjustable Dumbbell
 (1Pair+Bracket)**
 Size:380*335*130mm
 Machine Weight:15kg



C43

Sissy Squat
 Size:875*715*500mm
 Machine Weight:24.5kg



C80

**Multi-functional
 Smith Machine**
 Size:1970*1700*2280mm
 Machine Weight:270.5kg



C81

**Multi-functional
 Smith Machine**
 Size:2000*1500*2280mm
 Machine Weight:390.5kg



C90

**Multi-functional
 Smith Machine**
 Size:1965*2035*2280mm
 Machine Weight:448kg



C86

**Multi-functional
 Smith Machine**
 Size:2005*1920*2280mm
 Machine Weight:577kg



C75

Multi-Bench

Size:1500*710*1120mm
Machine Weight:47.5kg



C85

Multi-functional Squat Rack

Size:1720*1475*2350mm
Machine Weight:146kg



C95

Standing Abductor

Size:1720*830*1480mm
Machine Weight:158kg



C74

Free Weight Multi-gym

Size:1510*1440*2125mm
Machine Weight:95kg



C45

Calf Stretcher

Size:640*390*120mm
Machine Weight:8kg



C88

Dumbbell Rack

Size:540*575*570mm



TXD030

3D Smith Machine

Size:2585*2205*2425mm
Machine Weight:113kg



C53

Training Rack

Size:4440*3590*2805mm
Machine Weight:350kg

**C03****Overhanging TRX Rack**

Size:2605*2180*2790mm

Machine Weight:113kg

**C05****Overhanging TRX Rack**

Size:5220*4090*2370mm

Machine Weight:229kg

**C07****Free Training Rack**

Size:5500*2480*2850mm

Machine Weight:389kg

**C09****Bench Press Rack**

Size:4325*1505*2550mm

Machine Weight:358kg

**C12****Customized Squat Rack**

Size:1815*1405*2505mm

Machine Weight:158kg

**C13****Free Training Rack**

Size:5500*2481*2853mm

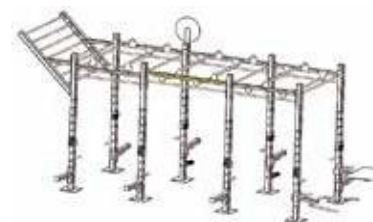
**C15****Climbing Ladder**

Size:6155*2695*3020mm

Machine Weight:397kg

**C16****Climbing Ladder**

Size:9880*3095*3695mm

Machine Weight:822kg



C17

Frame Squat Ladder

Size:4505*1530*2460mm

Machine Weight:330kg



C18

Parallel Ladder

Size:4470*680*2415mm

Machine Weight:177kg



C19

Wall Rack

Size:4070*1600*3005mm

Machine Weight:163kg



C20

Wall Rack

Size:3150*1130*300mm

Machine Weight:74kg

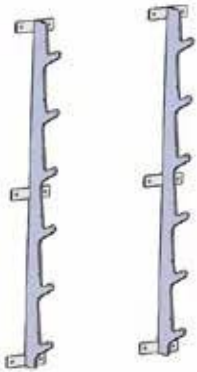

C21

Wall Rack

Size:200*205*1550mm

Machine Weight:35kg



C22

Sandbag Rack

Size:800*1405*2145mm

Machine Weight:63kg



C24

Combination Training Frame

Size:9020*3810*4050mm

Machine Weight:1762kg



C25

Climbing Ladder

Size:5800*3485*3695mm

Machine Weight:576kg

**C26****Wall Training Rack**

Size:725*1420*2400mm

Machine Weight:106kg

**C30****Climbing Ladder**

Size:7080*3245*2605mm

Machine Weight:707kg

**C31****Wall Rack**

Size:4970*2120*3010mm

Machine Weight:181kg

**C33****Commodity Shelf**

Size:2140*640*1460mm

Machine Weight:108kg

**C34****Climbing Ladder**

Size:7080*3245*2610mm

Machine Weight:765kg

**C35****Training Rack**

Size:7040*1715*3125mm

Machine Weight:244kg

**C36****Climbing Ladder**

Size:6130*3245*2610mm

Machine Weight:735kg

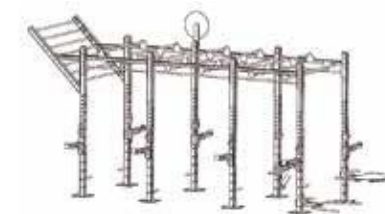
**C37****Climbing Ladder**

Size:6155*2705*3040mm

Machine Weight:506kg



C38

Climbing Ladder

Size:7080*3250*3130mm

Machine Weight:787kg

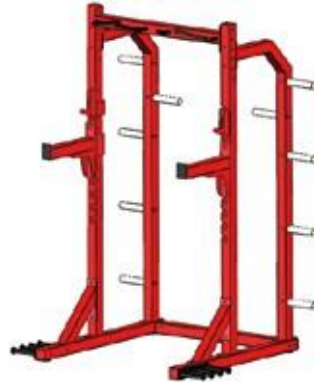

C42

Customized Squat Rack

Size:1775*1405*2475mm

Machine Weight:152kg



C44

Climbing Ladder

Size:8015*3090*3700mm

Machine Weight:767kg

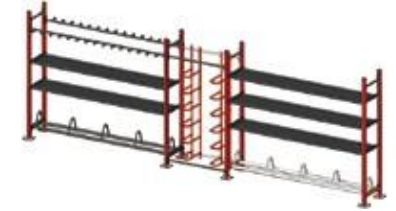

C52

Big Commodity Shelf

Size:5920*660*2010mm

Machine Weight:506kg

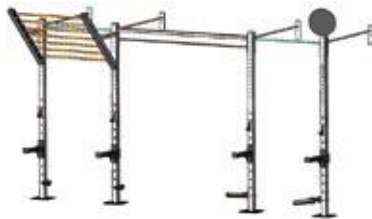

C46

Wall Training Rack

Size:5085*2605*3470mm

Machine Weight:221kg



C47

Bench Press Frame

Size:1815*1405*2175mm

Machine Weight:161.5kg



C50

Wall Training Rack

Size:5160*1600*3070mm

Machine Weight:244kg

Accessories Series



WG001

Dumbbell

Machine Weight:2.5kg-50kg
7.5kg...50kg



WG425

HealthFit Dumbbell

Machine Weight:2.5kg/5kg/
7.5kg/...50kg



WG424

HealthFit Weight Plate

Machine Weight:2.5KG/5KG/
10KG/15KG/
20KG/25KG



WG012

3 Holes Weight Plate

Machine Weight:2.5kg/5kg/
10kg/15kg/
20kg/25kg



WG055

Adjustable Barbell

Machine Weight:1kg/2.5kg/5kg



WG260

Fitness Handles



WG255

Rubber Flooring

Size:500x500mm



LL135

BIA Physical
Fitness Instrument

Size:799*452.5*1100mm

Machine Weight:16kg



This catalogue is only for your reference.If any difference about color or size, please contact your sales for final interpretation and thank you for your understanding